

# The Comparison of Genset Machine CS 1000 L Performance Between LPG and Methane Gas Usage as The Fuel

*Caturwati Ni Ketut*<sup>1,a</sup>, *Agung Sudrajad*<sup>1</sup>, *Mekro Permana*<sup>1</sup>, *Heri Haryanto*<sup>2</sup> and *Rizka Khaerani*<sup>1</sup>

<sup>1</sup>Mechanical Engineering Department- Universitas Sultan Ageng Tirtayasa,

<sup>2</sup>Electrical Engineering Department- Universitas Sultan Ageng Tirtayasa,

**Abstract.** Increasing demand of the energy along with the depletion of the world oil reserves had forced us to utilize the alternative energies in our daily life. One of those is that we should develop its utilization on biogas which a source of renewable energy and be able to overcome the problems that caused by the abundance of organic waste around us. Methane is a major element which found in biogas, therefore a preliminary study of the biogas utilization as resource of energy in a power plant can be preceed by the use of methane as a fuel gas in genset. This study compares the performance of CS 1000 L generator set that use methane gas fuel and LPG gas fuel. The results shows that the efficiency of thermal generator using methane fuel reaches 26.22 %. This value is higher than thermal efficiency genset that using LPG gas which only reaches the value of 8,26 %.

## 1 Introduction

Fuel oil is the main energy source used in human life today. This is because this fuel is easier to find and also easier to transportation handle. However, the oil prices are increasing along with the depletion of world oil reserves. This condition forces us to switch to using the other types of fuels such as coal and gas as much as possible to replace the use of fuel oil. In 2012 the Indonesian government issued an energy conversion policy by revoking oil price subsidies and carrying out a national campaign to use gas as the main fuel for cooking needs.

The types of natural gas used today are Liquid Petroleum Gas (LPG) and Compressed Natural Gas (CNG). LPG is a gas produced from refining petrolleum with the main content of propane (C<sub>3</sub>H<sub>8</sub>) and butane (C<sub>4</sub>H<sub>10</sub>) and a few other light hydrocarbons such as ethane (C<sub>2</sub>H<sub>6</sub>) and pentane (C<sub>5</sub>H<sub>12</sub>). While CNG is a natural gas with the main composition of methane (CH<sub>4</sub>). In addition, at this time various organic waste processing technologies were developed to produce biogas fuels which contained the main element of methane gas. Biogas is an alternative energy source that is environmentally friendly and renewable, which is produced from anaerobic fermentation by microorganisms in organic materials,

---

<sup>a</sup> Corresponding Author : [n4wati@untirta.ac.id](mailto:n4wati@untirta.ac.id)

such as agricultural waste, livestock manure, human waste and household waste [1][2][3][4][5][6].

Methane gas can also be produced naturally from piles of waste using landfill methods. The thing that must be considered is that methane gas is one of the gases included in the group of greenhouse gases which release freely into the atmosphere can cause an increase in global warming. To reduce this problem, methane gas can be used as fuel first before being released freely into the atmosphere.

Based on the description above, it is necessary to intensify the use of biogas as an alternative fuel in addressing our energy needs. For this reason, this experiment was carried out by testing the performance and exhaust emissions of LPG-fueled generators using methane as its fuel.

## 2 Method of Experiment

Experiments to test the performance and the emissions of type 1000 L generators using LPG as fuel compared to the performance of the same engine using methane as fuel are carried out with the composition of the test equipment as shown in Fig. 1.

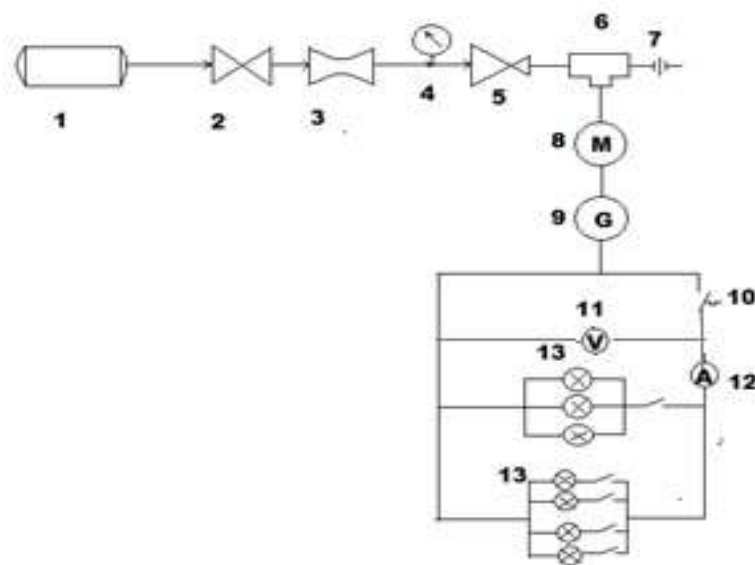

- 1. gas vessel
- 2. valve
- 3. flow meter
- 4. manometer
- 5. Reducer
- 6. carburator
- 7. orifice (air inlet)
- 8. Engine
- 9. Generator
- 10. circuit breaker
- 11. Voltmeter
- 12. Amperemeter
- 13 lamp loads

**Fig. 1.** Genset performance test equipment scheme

Genset engine performance test is carried out with variations in lamp load of: 0, 200, 400, 600, 700, 725 and 750 Watts by adjusting the number of lights installed. The amount of fuel flow is measured by a rotameter while the amount of air entering the engine combustion chamber is measured by an orificemeter.

### 3 Results and Discussion

Tests were carried out on the HL 1500 LX generator set using LPG and methane fuels, the installed lamp loads varied by 200, 400, 600, 700, 725, and 750 Watts, but the methane fuel generator test could only run up to 700 Watt.

#### 3.1 Indicated Horse Power (IHP)

IHP is the total amount of power developed by an engine which is resulted from multiplying the measured voltage value and the measured electric current.

$$IHP = V \times I \times \cos \phi \quad (1)$$

Fig. 2 shows the value of the IHP generator with LPG fuel and methane gas fuel. In general the value of the IHP is above the installed lamp load. In addition, the test results show that the use of methane fuel in generators produces a higher IHP than LPG, but the maximum light load that can be installed on a generator with methane fuel is lower than LPG.

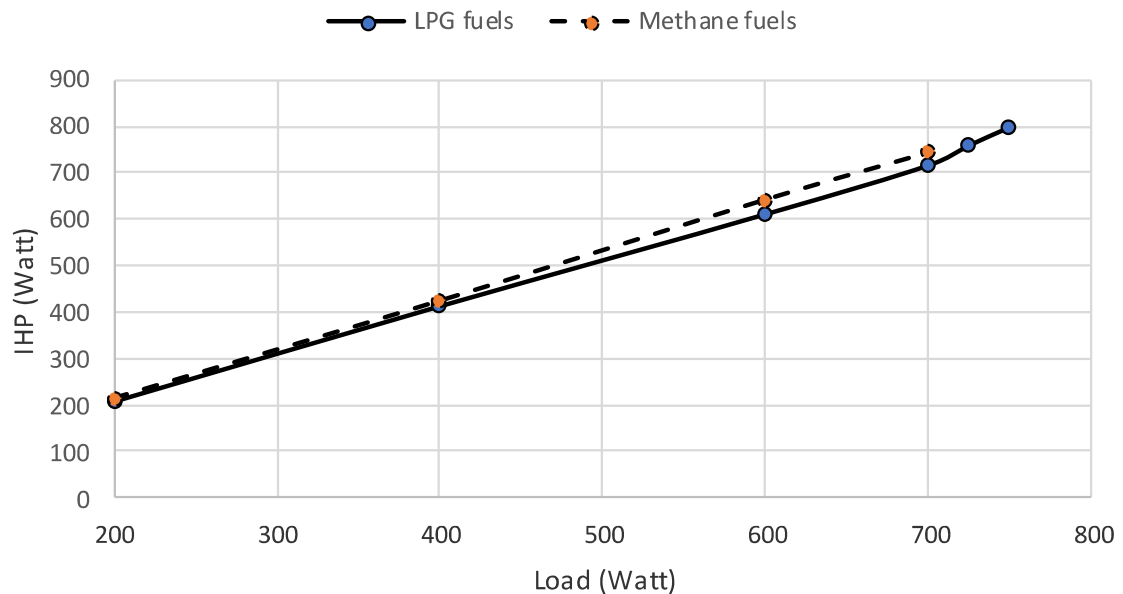

**Fig. 2.** The value of IHP for various lamp load on the generator.

#### 3.2 Specific Fuel Consumption (SFC)

SFC is the fuel efficiency of an engine with respect to the output.

$$SFC = \frac{m_f}{IHP} \quad (2)$$

Where :  $\dot{m}_f$  is mass flow rate of fuel (kg/s) and it can be determined from the flow rate of gas volume

$$\dot{m}_f = \rho_f \cdot \dot{Q}_f \quad (3)$$

Fig. 3 shows that in general the value of the SFC generator is lower with the increase in the load of the installed lamp. In particular, the use of methane fuel in generators is much lower than LPG fuel.

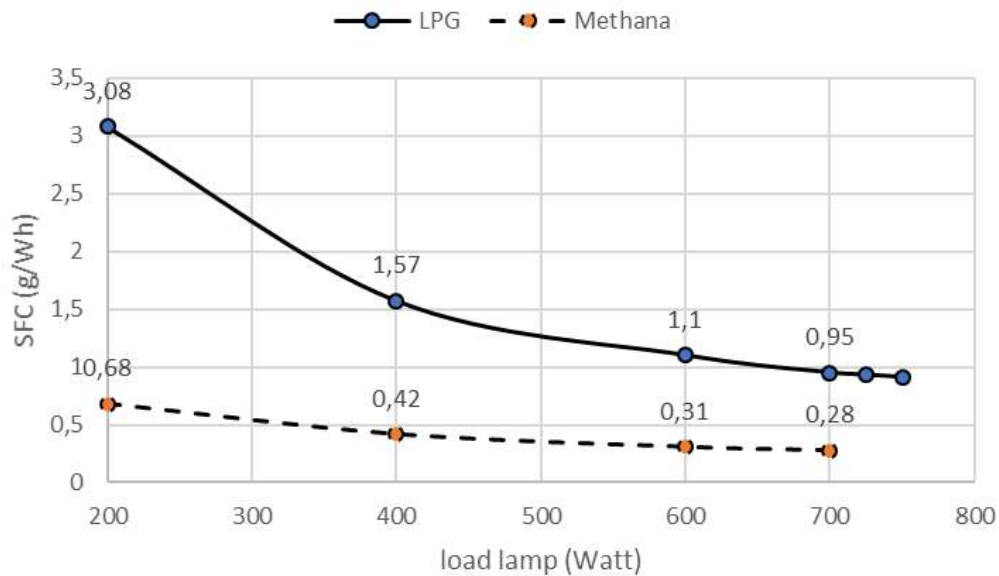

**Fig. 3.** The value of SFC for various load lamp.

### 3.3 Thermal Efficiency

Thermal efficiency is a dimensionless performance measure of a device that uses thermal energy, such as an internal combustion engine. Or the thermal efficiency is the size and magnitude of the heat energy contained in a fuel that can be converted to be a useful power, theoretically can be formulated as follows :

$$\eta_{th} = \frac{IHP}{\dot{m}_f \times LHV} \times 100 \% \quad (4)$$

Where LHV is lower heat values of the fuel. LHV of LPG (50 % Propana; 50 % Butana) is 46.050 kJ/kg and LHV of methane (CH<sub>4</sub>) is about 50.000 kJ/kg. So the value of the thermal efficiency of the generator with LPG and methane gas is shown in Fig. 4.

The value of thermal efficiency in general increases with the increasing value of the load installed on the generator. In addition, the thermal efficiency of methane gas is higher than the thermal efficiency of LPG gas.

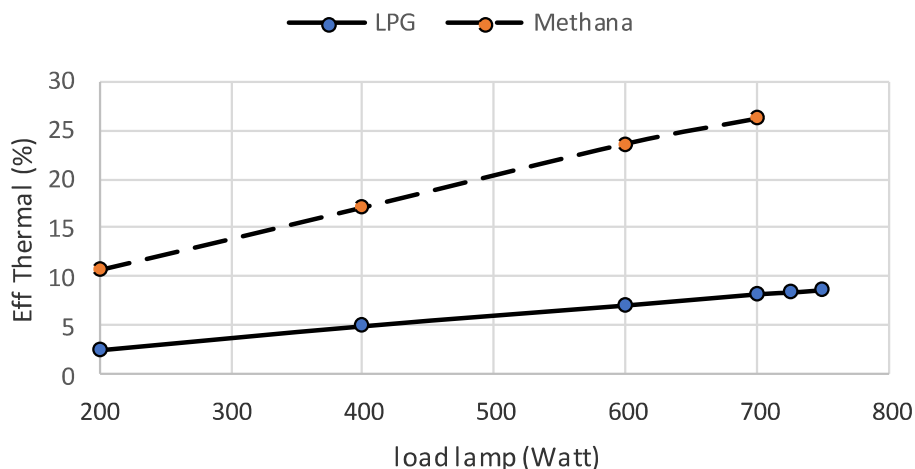

**Fig. 4.** Thermal Efficiencies of genset with methana and LPG as fuel

## 4 Conclusions

The use of methane gas as fuel for the LPG gas generator set can improve engine performance which is marked by the value of the IHP generated by the generator is always above the installed lamp load. The difference in the value of the IHP and the lamp load installed on the methane gas-fueled generator set reaches an average of 6.4% while the average LPG-fueled generator set is only 3.47%. So that in general the use of methane fuel in the generator produces greater output power than LPG. So that in general the use of methane fuel in the generator produces greater output power than LPG.

Fuel consumption for generator sets with methane gas fuel is lower than LPG gas fuel which is indicated by the SFC values. The value of SFC genset with methane as the fuel and load installed of 700 W is 0.28 g / WH, while the value of SFC generator with LPG fuel at the same load reaches 0.95 g / WH. This shows the use of methane gas as fuel generator is 30% of the amount of LPG gas needed.

The thermal efficiency of the generator with methane gas fuel can reach 26.22% when the installed load is 700 Watts, while the use of LPG fuel only produces a maximum value of thermal efficiency of 8.62% when the load is installed at 750 Watts of the several advantages above, the use of methane as a fuel in a generator set reduces the generator load capacity. The test results show that the installed load capacity for methane gas-fueled generators reaches 700 Watts, this value is lower than LPG gas which reaches 750 Watts.

## 5 Acknowledgment

The authors would like to thank the Ministry of Research and Higher Education of Republic of Indonesia for the financial support under PTUPT Research Grant.

## References

1. S. Amini, P. Ordoney, and I. Khuzestan, "Investigation of biogas as renewable energy source.," *Int. J. ...*, pp. 1453–1457, (2013).
2. R. Arthur, M. F. Baidoo, and E. Antwi, "Biogas as a potential renewable energy

- source: A Ghanaian case study,” *Renew. Energy*, vol. 36, no. 5, pp. 1510–1516, (2011).
3. L. G. a Potts and D. J. Martin, “Anaerobic digestion, gasification, and pyrolysis,” *Waste Manag. Minimization*, (2011).
  4. J. Fierro, “Best Available Techniques in Pyrolysis and Anaerobic Digestion Introduction : Pyrolysis,” no. September, pp. 29–30, (2011).
  5. K. Jonasson, “Project 3 . Biomass to energy and chemicals through anaerobic digestion and gasification Kevin Jonasson Sebnem Madrali NRCan - Bioenergy Development Group.”
  6. C. N. Ketut, A. Sudrajad, M. Permana, and H. Haryanto, “Experimental study of anaerobic digester biogas method using leachate from landfill municipal waste,” *Int. J. Appl. Eng. Res.*, vol. 12, no. 19, pp. 9112–9115, (2017).