

# LAMPIRAN

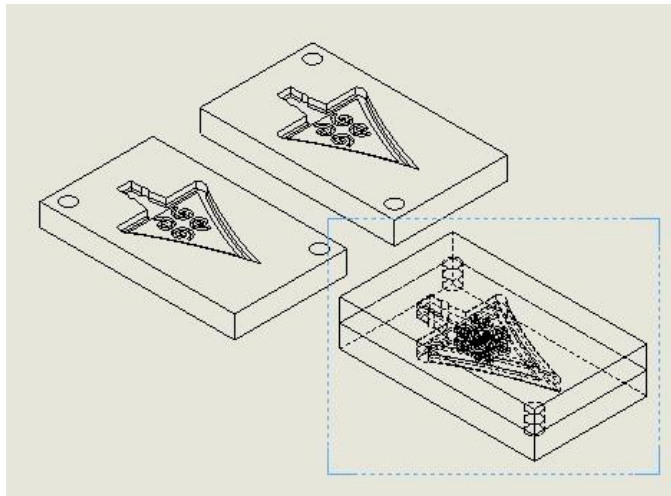

## L1. Desain Cetakan

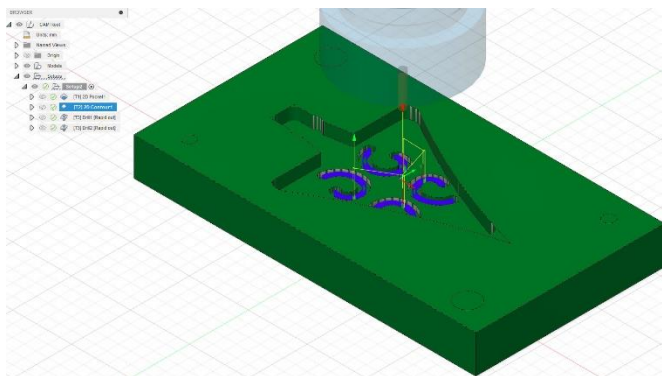

## L2. Proses Pembuatan CNC



### L3. Monitor Pemrograman CNC



### L4. Proses Pembuatan Cetakan



### L5. Cetakan

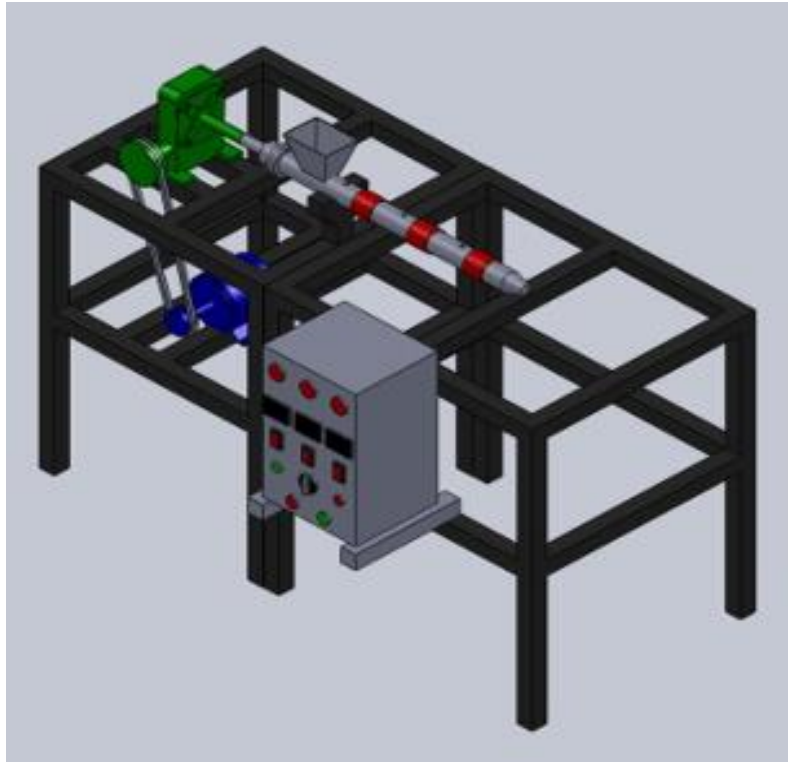

**L6. Mesin Injection Molding**

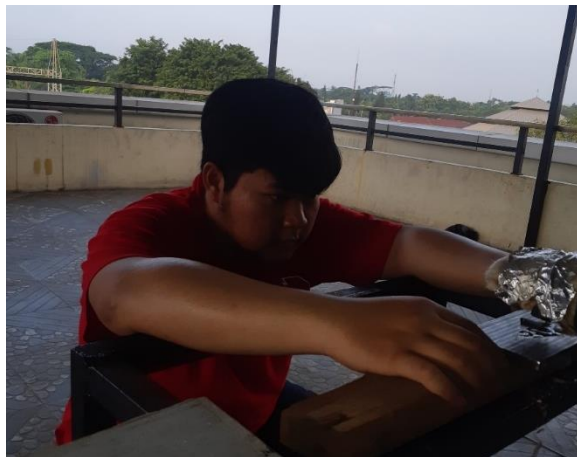

**L7. Proses**



**L8.** Hasil Produk Setelah Dilakukan proses  
*Injection Moulding*



**L9.** Produk Ornamen Pagar



**L10. Universal Testing Machine MTS Landmark**

100 kN