

# Analyze of Geometric Characteristic of Powder Reinforced Composite Material from Liquid Waste for Part of Motor Vehicle

Hendra<sup>1,a\*</sup>, Pudi Virama<sup>2,b</sup>, Hernadewita<sup>3,c</sup>, Dhimas Satria<sup>1,d</sup>, Hermiyetti<sup>4,e</sup>,  
Frengki Hardian<sup>5,f</sup>

<sup>1</sup>Mechanical Engineering, University of Sultan Ageng Tirtayasa, Banten, Indonesia

<sup>2</sup>Mechanical Engineering, Faculty of Engineering, University of Bengkulu, Bengkulu, Indonesia

<sup>3</sup>Magister Industrial Engineering, University of Mercubuana, Jakarta, Indonesia

<sup>4</sup>Faculty of Economic, University of Bakrie, Jakarta, Indonesia

<sup>5</sup>Magister Notary, University of Yarsi, Jakarta Indonesia

<sup>a</sup>hendra@untirta.ac.id, <sup>b</sup>h7f1973@yahoo.com, <sup>c</sup>hernadewita@mercubuana.ac.id,  
<sup>d</sup>dhimas@untirta.ac.id, <sup>e</sup>hermiyetti@gmail.com, <sup>f</sup>h7frengki@gmail.com

**Keywords:** Composite, Particles, a body of the motor vehicle, Casting, Dimension, Surface Roughness.

**Abstract.** A composite material is a combination of two or more materials that have advantages such as being lightweight, higher strength, corrosion resistance, and low installation cost [1]. Composite materials are commonly found in aircraft, automotive, manufacturing, and other industries [2,4]. Composite materials based on the type of reinforcement consist of types of fibers, particles, and structures [5-14]. In this study, the particle composite material is made from a reinforcing powder made from liquid waste and used for the manufacture of motor vehicle body products (wing or bottom components). Composite reinforcing materials from liquid waste are obtained through the process of drying palm liquid waste or rubber in powder form. The manufacturing process of two-wheeled motor vehicle body products uses a casting process by making molds and products using the hand-laying coating method. The alloying material used in this research is Yukalac 156 BQTN-EC resin and reinforcement from liquid palm oil or rubber waste powder. The variation of the alloy becomes a parameter to evaluate the quality of the casting product analyzed in the form of the geometric characteristics of the product i.e. the dimensions and surface roughness. Variations of composite material alloys use a ratio of 1:1 to 5:1. From the results of the study, it is found that the dimensions are close to the design value with the smallest deviation at a composition ratio of 3:1 which surface roughness values is 2.18 to 3.13  $\mu\text{m}$  for mold dies and 6.45 to 8.02  $\mu\text{m}$  for the product.

## Introduction

Composite materials are part of the science of materials engineering that aims to obtain better mechanical properties. Composite materials are parts of advanced materials that have better mechanical properties criteria than metals or other materials. A composite material is a combination of two or more materials that have different constituent elements. Composite materials have advantages such as being lightweight, higher strength, corrosion resistance, and low installation costs.

Composite materials are commonly found in aircraft, automotive, manufacturing, and other industries. Composite materials based on the type of reinforcement consist of types of fibers, particles, and structures [5-14]. Fiber composite materials are made of fiber reinforcement, particle reinforcement, or powder particle composite and sheet reinforcement structural composites. Other composite materials namely thermoplastic and thermoset. [14-16]

In this study, the particle composite material is made of reinforcement powder made from liquid waste and used for the manufacture of motor vehicle body products (wing or bottom components). Composite reinforcing materials from liquid waste are obtained through the process of drying liquid palm oil or rubber waste using a rotary dryer in powder form [12-13]. The process of making

two-wheel motor vehicle body products from composite materials using casting process by making molds and products using the hand-laying coating method. The alloying composite material used in this research is Yukalac 156 BQTN-EC resin and powder reinforcement from liquid palm oil or rubber waste.

By diversifying the alloy between resin and powder reinforcement, the product will be obtained in the form of a two-wheeled vehicle body and a product quality assessment is carried out which includes geometric features such as dimensions and surface roughness of the product. Variations of composite material alloys use a resin ratio and a reinforcement ratio of 1: 1 to 1: 5.

## Research Method

This research method uses an experimental method by making a two-wheel motor vehicle body product from a composite material made of reinforcing powder from the drying of palm liquid or rubber waste. Liquid palm or rubber waste is obtained from the palm oil or rubber processing industry in the form of liquid waste from palm oil processing or crude rubber processing. The liquid palm or rubber residue is dried using a rotary dryer at a temperature of 110<sup>0</sup>C to produce a powder. The powder from this waste drying is used as a reinforcing element in the manufacture of composite materials as shown in Fig. 1. Powder-reinforced composite materials used for the manufacture of two-wheeled motor vehicle body components consist of resin, palm oil waste, catalyst, mirror glaze as can be seen in Figs. 1 to 3.

The composite material for the body of a two-wheeled motor vehicle in the form of a wing or lower body is made of Yukalac resin alloy and reinforcing powder from the liquid waste drying process. Composite materials made by hand casting process have a resin and reinforcement composition of 1: 1 to 1: 5 and weight total for mold dies 600 gr and 250 gram for a product as shown in Table 1.

The design of body dimensions of the two-wheeled motor vehicle has a height of 155 mm, a length of 200 mm, and a thickness of 5 mm (see Figure 4). The process of making two-wheel motor vehicle body components consists of making design drawings, mold patterns, molds, castings of mold dies and components, geometric analysis includes measuring component dimensions, surface roughness, and product shape. Design drawings, die patterns/products, mold dies, and products can be seen in Figs. 5-7. The mold dies pattern is made out of cardboard and then the mold is made using the hand layup casting method. Followed by making the product using a mold that has been coated with glass glaze so that the product components do not stick to the mold. After the components are formed, geometric tests are carried out by measuring the dimensions, shape, and surface roughness values of the component or product.

Table 1 Composition of composite material for dies and product (body of the motor vehicle)

Composition (Resin and Reinforcement)	Weight total of dies [gr]	Weight total of Product [gr]
1:1	600	250
2:1		
3:1		
4:1		
5:1		
6:1		

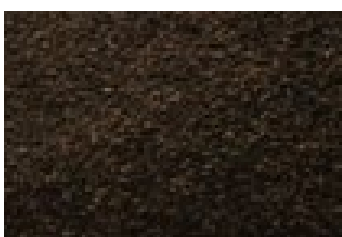

Fig. 1 Reinforcement element

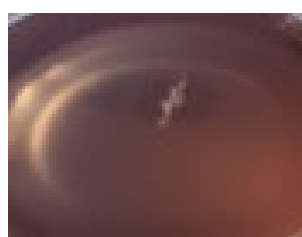

Fig. 2. Yukalac resin

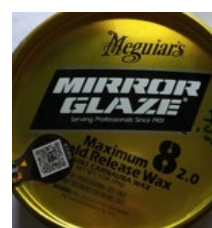

Fig. 3 Mirror glaze

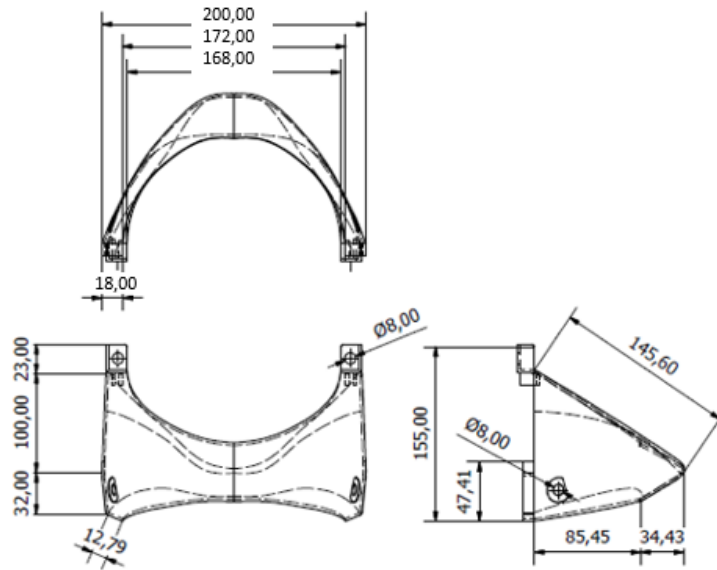

Fig. 4 Dimension of product [mm]



Fig.5 Patterns



Fig. 6 Dies of product



Fig. 7 Product

The position of the measuring point for the surface roughness value includes the front, side and top components of the body of a two-wheeled motor vehicle as can be seen in Fig. 8. Dimensions and surface roughness are measured using a caliper and surface roughness tester [17]. The specifications of the surface roughness tester can be seen in Table 2 and Fig. 9 which has a range of roughness measurements between 0.01 to 40  $\mu\text{m}$ .

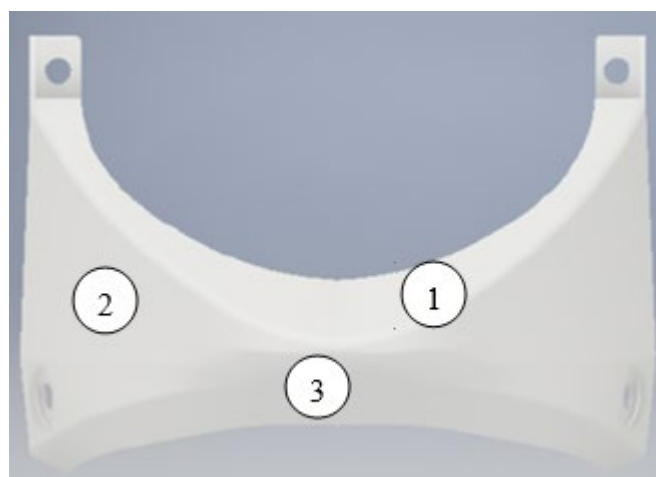

Fig 8. Position of measurement surface roughness

Table 2 Specification of surface roughness tester TR 200

Standard	ISO/JIS/DIN/ANSI
Range	Ra 0.01 – 40 $\mu\text{m}$



Fig. 9 Surface roughness tester

The stage of research process begins by observing the body components of a two-wheeled motor vehicle, the materials used and the shape of the body components. From the advantages and disadvantages of material two-wheel motor vehicle body components, preliminary studies have been conducted to select materials and manufacturing methods that can be used as two-wheel motor vehicle body components. Then continuous by the preparation of equipment and the manufacturing process of motor vehicle body components using the casting process. The hand-layup method is chosen for the casting process of the body components followed by making the patterns, molds, and products. Molds and casting products are measured for dimensions, surface roughness, and shape (geometric characteristic) for evaluation quality of product/component. Next, it is analyzed and inferred from the results of the use of composite materials made from liquid waste for two-wheeled motor vehicle body components. The flow chart of this research process can be seen in Fig. 10.

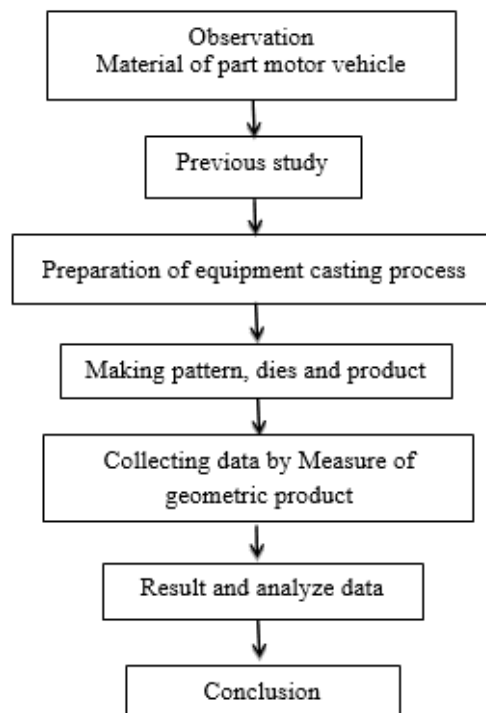

Fig. 10 Flowchart of reserach



## Results and Discussion

The results of manufacturing two-wheel motor vehicle body products in the form of mold die and products using hand lay-up method casting process can be seen in Figure. 6-7. Mold dies and product shapes are measured and compared to design specifications. The result of making the die for a 1:1 ratio of resin and powder reinforcement from liquid waste using the casting process obtained top dimensions of length 147.3 mm, height 44.7 mm, weight 430 gr, and surface roughness value of 5,865

$\mu\text{m}$ . For side measurements, the length was 152 mm and height 113.5 mm with a surface roughness value of 7,670  $\mu\text{m}$ . Measurements on the front of the body of a two-wheeled motor vehicle obtained a length of 32.22 mm, a height of 77.01 mm, and a surface roughness value of 4,580  $\mu\text{m}$ .

The results of mold measurements for motor vehicle body components with a 1:1 composition show that the front surface roughness is smoother than the top and sides. This indicates that the result of the casting process is uneven because of the ratio between the resin and the same amount of waste. For the measurement results, all parts shall have the same surface roughness and smoothness values to facilitate the flow of water or fluid when it touches the front of the body of a two-wheeled motor vehicle. The shapes and measurement results of the wing products or underside components of two-wheeled motor vehicles can be seen in Table 3.

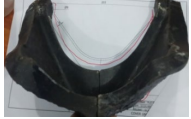
Table 3 Result of dies using composition of composite material 1:1

Point of measure	Shape	Part	Position	Dimension of design [mm]	Dimension of product [mm]	Weight of dies [gr]	Average of surface roughness value [ $\mu\text{m}$ ]
1		On top	Height		44,57	430,00	5,87
			Length		147,30		
2		Side	Height		152,00		7,67
			Length		113,13		
3		Front	Height		77,01		4,58
			Length		32,22		



For the die casting process result with 3:1 composition resin and powder reinforcement from liquid waste, the surface roughness result is smoother than the 1:1 composition as shown in Table 4. The measurement dimension and surface roughness values for the top are 152.78 mm in length, 46.10 mm in height, and 2.95  $\mu\text{m}$  in surface roughness values. The measurement of sides has a length value of 154.99 mm, a height of 112.78 mm, and a surface roughness of 2,180  $\mu\text{m}$ . At the front, the length measurement of the motor vehicle body component is 32.28 mm and height 107.71 mm with a surface roughness of 3.03  $\mu\text{m}$ . From the initial design of the dies, it can be seen that this size has a value almost equal to the design of the composite material casting product.

The results of the casting process for two-wheeled motor vehicle body components with compositions resin and powder reinforcement from liquid waste 0, 1:1, and 3:1 are shown in Table 3. In Table 3 it can be seen that the surface roughness results of 3:1 composition resin and powder reinforcement from liquid waste are smoother than the 1:1 composition. The measurement results show that dimensions for the top were 152.78 mm long, 46.10 m high, and surface roughness value 2.95  $\mu\text{m}$ . The sides have a dimension with a length value of 154.99 mm, a height of 112.78 mm, and a surface roughness of 2,180  $\mu\text{m}$ . At the front, the length measurement of the motor vehicle body component is 32.28 mm and height 107.71 mm with a surface roughness of 3.03  $\mu\text{m}$ . From the initial design of the dies, it can be seen that this size has a value almost equal to the design of the composite material casting product.

The results of the casting process for two-wheeled motor vehicle body components with resin and powder reinforcement from the liquid waste composition of 0, 1:1, and 3:1 can be seen in Table 5. Table 5 shows the smoother surface roughness results of the front with resin and powder reinforcement from the liquid waste composition. 3:1. While for the upper and side components of the

body of a two-wheeled motor vehicle, the composition of resin and powder reinforcement from liquid waste 1:1 has a higher fineness compared to other compositions. Composition 0 was used as a comparison to determine the strength of the resin material as part of the body components of a two-wheeled motor vehicle.

Table 4 Result of dies using composition of composite material 3:1

Point of measure	Shape	Part	Position	Dimension of design [mm]	Dimension of product [mm]	Weight of dies [gr]	Average of surface roughness value [ $\mu\text{m}$ ]		
1		On top	Height		46,10	380,00	2,95		
			Length		152,78				
2		Side	Height		112,78		380,00	2,18	
			Length		154,99				
3		Front	Height		107,71			380,00	3,03
			Length		32,28				

In terms of the manufacturing dimensions of the body components of two-wheeled motor vehicles, it can be seen that the composition of resin and powder reinforcement from liquid waste 3:1 has a dimensional measurement value that is closer to the design value. Where the design dimensions covering height, length, and thickness are 172 mm, 145 mm, 3 mm for the upper body components of a two-wheeled motor vehicle. For the body components of two-wheeled motor vehicles which are 155 mm, 112 mm, 3 mm, and the upper part of the body components of two-wheeled motor vehicles which are 47.41 mm, 85.45 mm, 3 mm. The measurement result for two-wheeled motor vehicle body components with 3: 1 resin and powder reinforcement from the liquid waste composition is 171 mm, 145 mm, 2.87 mm for the upper part of the two-wheeled motor vehicle body component, the side part of the two-wheeled motor vehicle body component is 154 mm, 119 mm, 2.97 mm and the upper body components of a two-wheeled motor vehicle are 47.35 mm, 84.04 mm and 2.99 mm.

From the results of the manufacture of two-wheeled motor vehicle body components using the casting process using the hand lay-up method and dimensional measurements using calipers and surface roughness testers, the best values were obtained on the 3:1 resin and powder reinforcement from the liquid waste composition as shown in Table 5.

For the deviation of dimensional values and surface roughness of two-wheel motor vehicle body components based on the ratio of resin and powder reinforcement from liquid waste from 1:1 to 5:1 can be seen in Figs. 11-12. Where the deviation of the dimensional values and surface roughness of the smoothest product for the body components of a two-wheeled motor vehicle is found in the ratio of resin and powder reinforcement from liquid waste 3:1 (see Figure 11-12).

Table 5 Result of product using variant composition resin and powder reinforcement from liquid waste for composite material 3:1

Composition Resin and liquid waste					0	1:1	3:1			
Point of measure	Shape	Part	Position	Dimension of design [mm]	Dimension of product [mm]	Average of surface roughness value [ $\mu\text{m}$ ]	Dimension of product (mm)	Average of surface roughness value [ $\mu\text{m}$ ]	Dimension of product (mm)	Average of surface roughness value [ $\mu\text{m}$ ]
1	 0  1:1  3:1	Front	Height	172,00	163,00	6,62	163,00	9,28	171,00	6,45
			Length	145,00	144,00		143,00		145,00	
			Thickness	3,00	1,47		2,55		2,87	
2	 0  1:1  3:1	Side	Height	155,00	152,00	5,58	154,00	7,00	154,00	7,80
			Length	111,88	116,00		118,30		119,36	
			Thickness	3,00	1,82		1,80		2,97	
3	 0  1:1  3:1	On top	Height	47,41	43,53	7,25	45,03	5,02	47,35	8,02
			Length	85,45	82,00		82,90		84,04	
			Thickness	3,00	1,03		2,70		2,99	

Fig. 10 a and b show the dimensional deviations result that occur from the manufacture of composite materials by the casting process using the hand lay-up method. The largest deviation in each product of a two-wheeled motor vehicle body component has a spreadsheet on each side of the measuring point. As in the front, sides, and on top, show that the difference in the resulting dimensional values. The casting results using the hand lay-up method close to the design value were obtained on a 3:1 composition resin and powder from liquid waste. In the composition of resins and other powders from liquid waste, there are significant differences between the front, side, and on top dimensions. Meanwhile, the surface roughness value has a similar value in the composition of resin and powder from liquid waste 2:1, but the surface roughness value is higher (rough) than the others

composition of composite material. For low surface roughness (smooth) obtained with a composition of resin and powder from liquid waste 5:1 as shown in Fig. 11. This indicates that the more liquid waste powder, the more solid the combination with the resin will be.

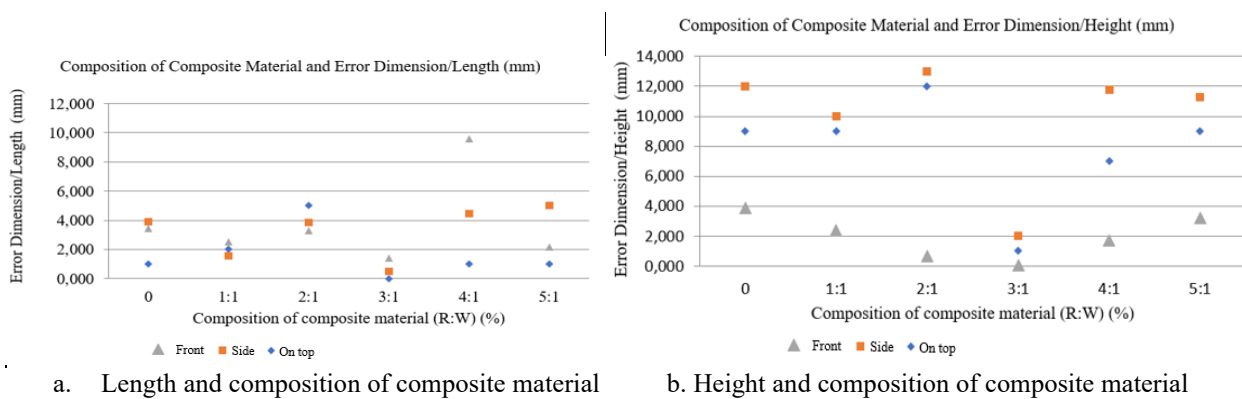

Fig. 10 Dimension and composition of composite material (product)

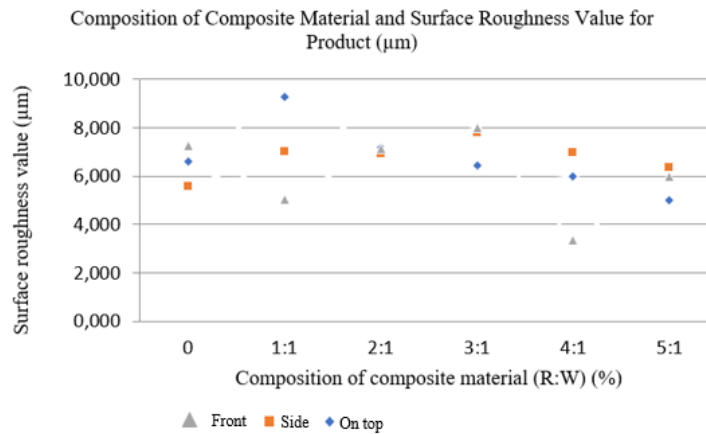

Fig. 11 Surface roughness value and composition of composite material (product)

## Conclusion

The manufacture of powder-reinforced composite materials by a casting process using the hand layup method for two-wheeled motor vehicle body components the following conclusions is the composition of resin and powder-reinforced from liquid waste composite materials affects the dimensions and surface roughness of mold dies and products. The casting results using the hand lay-up method are close to the design value were obtained on a 3:1 composition resin and powder from liquid waste. In the other components of resins and powders from liquid waste, there are significant differences between the front, side, and on top dimensions values.

By ratio 3:1 composition resin and powder-reinforced produces a dimension value is close with the dimensional design value of the product, i.e. the length 145 mm, height 171 mm and the thickness 2.87 mm for the front of the two-wheeled motor vehicle body component, the side part of the two-wheeled motor vehicle body component is 154 mm, 119 mm, 2.97 mm and on top of body components of a two-wheeled motor vehicle are 47.35 mm, 84.04 mm and 2.99 mm. The surface roughness was obtained from 6.45  $\mu\text{m}$  to 8.02  $\mu\text{m}$ .

For die with 3:1 composition resin and powder reinforcement from liquid waste, the surface roughness result is smoother than the 1:1 composition. The measurement dimension and surface roughness values for the top are 152.78 mm in length, 46.10 m in height, and 2.95  $\mu\text{m}$  surface roughness values. The measurement of sides has a length value of 154.99 mm, a height of 112.78 mm, and a surface roughness of 2,180  $\mu\text{m}$ . At the front, the length measurement of the motor vehicle body component is 32.28 mm and height 107.71 mm with a surface roughness of 3.03  $\mu\text{m}$ .



The surface roughness value has a similar value in the composition of resin and powder from liquid waste 2:1, but the surface roughness value is higher (rough) than the other components of composite material. For low surface roughness (smooth) was obtained with a composition of resin and powder from liquid waste 5:1.

### Acknowledgments

This research was support by the Ministry Research, Technology and the Higher Education Republic of Indonesia through Hibah Kompetensi 2016-2018 and Institution of Research and Community Service University of Bengkulu

### References

- [1] M.Ö. Seydibeyoğlu, A. Dođru, M.B. Kandemir, and Ö. Aksoy, *Lightweight Composite Materials in Transport Structures*, Book Chapter In book: *Lightweight Polymer Composite Structures*, 2020.
- [2] Gardiner G., *Thermoplastic Composites Gain Leading Edge on the A380*. *High-Performance Composites* 14:50–55 16, 2006.
- [3] Soutis, C., *Aerospace Engineering Requirements in Building with Composites*, in book: *Polymer Composites in the Aerospace Industry*, pp.3-22, 2020. Available at: <http://www.sciencedirect.com/science/article/pii/B9780081026793000010>
- [4] J.W. Van Ingen, A. Buitenhuis, M. Wijngaarden and F. Simmons, *Development of the Gulfstream G650 induction welded thermoplastic elevators and rudder*, Conference: *Sampe Seattle*, 2010.
- [5] P.H. Aditya, K.S. Kishore, D.V.V. K. Prasad, *Characterization of Natural Fiber Reinforced Composites*, *International Journal of Engineering and Applied Sciences (IJEAS)* ISSN: 2394-3661, Volume-4, Issue-6, 2017.
- [6] D.K. Rajak, Durgesh, Pagar, Pradeep, Menezes and E. Linul, *Fiber-Reinforced Polymer Composites: Manufacturing, Properties, and Applications*, *Polymers*, 11, 1667, 2019.
- [7] L.C.M. Lebreton, J. Van Der Zwet, J.W. Damsteeg, B. Slat, A. Andrady, J. Reisser, *River Plastic Emissions to The World's Oceans*. *Nature Communication*, 8, 15611, 2017.
- [8] Scaffaro, R. Maio, A. Lopresti, F., *Physical Properties of Green Composites Based on Poly-Lactic Acid or Material-Bi Filled with Posidonia Oceanica Leaves*. *Compos. Part. A. Appl. S.*, 112, 315–327, 2018.
- [9] A. Singh, S. Singh, A. Kumar, A. Kumar, *Characterization of Novel Coconut Shell Powder Reinforced - Epoxy Composite*, *Journal of Engineering And Technology Research*, 2 (5):1-7, 2014.
- [10] Nurhasanah, M., Helmi, "Kajian Pemanfaatan Serbuk Papan sebagai Bahan Alternatif Campuran Resin dengan Metode Pattern Hole Drying untuk Perbaikan dan Perawatan Kapal" *Jurusan Teknik Perkapalan Politeknik Negeri Bengkalis*. Vol. 8, No. 1, 2018. ISSN 2088-6225. E-ISSN 2580-2798.
- [11] P.N. Raharjo, "Studi Banding Teknologi Pengelolaan Limbah Cair Pabrik Kelapa Sawit" *Teknologi Lingkungan Badan Pengkajian dan Penerapan Teknologi*. Vol.10. No.1. Januari 2009. ISSN 1441-318X.
- [12] Hendra, A. Indriani, Hernadewita, Y. Rizal, *Assembly Programmable Logic Control (PLC) in the Rotary Dryer Machine for Processing Waste Liquid System*, *Applied Mechanics and Materials*, Vol. 842, pp. 319-323, 2016, Trans Tech Publications, Switzerland.

- [13] Hendra, Syukriah, M. Silalahi, A. Indriani, Hernadewita and Hermiyetti, Finite Element Method Analysis for Manufacturing Design Drum Dryer of Rotary Dryer Machine, IOP Conf. Series: Materials Science and Engineering 505, 2019, 012133 IOP Publishing doi:10.1088/1757-899X/505/1/012133.
- [14] S.J. Pickering, Recycling Technologies for Thermoset Composite Materials—Current Status. *Compos A: Appl. Sci. Manuf.* 37(8): 1206–1215, 2006.
- [15] L. Sadik, Omairey, Sofia, Sampethai, Luka, Hans, Chris, Worrall, S. Lewis, D. Negro, Development of Innovative Automated Solutions For The Assembly Of Multifunctional Thermoplastic Composite Fuselage, *The International Journal of Advanced Manufacturing Technology* (2021) 117:1721–1738. <https://doi.org/10.1007/s00170-021-07829-2/>.
- [16] M. Sun, X. Sun, Z. Wang, M. Chang, H. Li, The Influence of Shape Memory Alloy Volume Fraction on the Impact Behavior of Polymer Composites, *Polymers* 2018, 10, 1280.
- [17] T. Rochim, Spesifikasi, Metrologi, dan Kontrol Kualitas Geometrik. Bandung: Laboratorium Produksi Mesin dan Metrologi Industri, Jurusan Teknik Mesin, ITB, 2006.