

Editor/Author Correspondence

Author Subject: Paper Status (Paper ID: 6363) [DELETE](#)

2017-05-30 05:51 PM
Dear Dr. Tole Sutikno
Managing Editor TELKOMNIKA

I have submitted my manuscript titled Shunt Active Power Filter based on P-Q Theory with Multilevel Inverters for Harmonic Current Compensation [manuscript id: #6363] to TELKOMNIKA via the online submission system on April 24, 2017. Two days later, the status changed to 'In Review.' However, the status has remained unchanged ever since.

I would be grateful if you could let me know whether there has been any further progress on my submission.

Sincerely,

Teguh Firmansyah
Corresponding author.
teguhfirmansyah@untirta.ac.id

TELKOMNIKA (Telecommunication Computing Electronics and Control)
<http://www.journal.uad.ac.id/index.php/TELKOMNIKA>

Author Subject: Shunt Active Power Filter based on P-Q Theory with Multilevel Inverters for Harmonic Current Compensation [DELETE](#)

2017-07-03 09:36 PM
Dear Dr. Tole Sutikno
Managing Editor TELKOMNIKA

I have submitted my manuscript titled Shunt Active Power Filter based on P-Q Theory with Multilevel Inverters for Harmonic Current Compensation [manuscript id: #6363] to TELKOMNIKA via the online submission system on April 24, 2017. Two days later, the status changed to 'In Review.' However, the status has remained unchanged ever since.

I would be grateful if you could let me know whether there has been any further progress on my submission.

Sincerely,

Teguh Firmansyah
Corresponding author.
teguhfirmansyah@untirta.ac.id

TELKOMNIKA (Telecommunication Computing Electronics and Control)
<http://www.journal.uad.ac.id/index.php/TELKOMNIKA>

Author Subject: Shunt Active Power Filter based on P-Q Theory with Multilevel Inverters for Harmonic Current Compensation [DELETE](#)

2017-07-11 06:40 AM

TELKOMNIKA (Telecommunication Computing Electronics and Control)
<http://www.journal.uad.ac.id/index.php/TELKOMNIKA>

Editor Subject: [TELKOMNIKA] Editor Decision [DELETE](#)

2017-08-20 09:59 AM
Dr. Teguh Firmansyah:

We have reached a decision regarding your submission to TELKOMNIKA (Telecommunication Computing Electronics and Control), "Shunt Active Power Filter based on P-Q Theory with Multilevel Inverters for Harmonic Current Compensation".

Our decision is to: Revisions required

In preparing your revised paper, you should pay attention to:

1. An Introduction should contain the following three parts:
 - Background: Authors have to make clear what the context is. Ideally, authors should give an idea of the state-of-the art of the field the report is about.
 - The Problem: If there was no problem, there would be no reason for writing a manuscript, and definitely no reason for reading it. So, please tell readers why they should proceed reading. Experience shows that for this part a few lines are often sufficient.
 - The Proposed Solution: Now and only now! - authors may outline the contribution of the manuscript. Here authors have to make sure readers point out what are the novel aspects of authors work.

Authors should place the paper in proper context by citing relevant papers. At least, 5 references (recently journal articles) are used in this section.
2. Results and discussion section: The presentation of results should be simple and straightforward in style. You should improve your analyzing and also present the comparison between performance of your approach and other researches. Results given in figures should not be repeated in tables. This section report the most important findings, including results of analyses as appropriate. It is very important to prove that your manuscript has a significant value and not trivial.
3. Prepare your figures in high quality and created by yourself (not copy and paste from other parties). All legends, captions ... in your figures MUST in English.
4. Please ensure that: all references have been cited in your text; Each citation should be written in the order of appearance in the text; The references must be presented in numbering. The references must be integrated also with not less than two papers published on:
 - IAES Journals at <http://iaescore.com/journals>
 - TELKOMNIKA at <http://journal.uad.ac.id/index.php/TELKOMNIKA>
 - Indonesian Journals at <http://journal.portalgaruda.org/index.php/eei>
 - IAES Section Journals at <http://section.iaesonline.com/index.php/ijeei>

Please prepare your revised paper perfectly consider the guide. Please get take a look at: <http://goo.gl/FiPFbF>

You should submit your revised paper through our online system within 8 weeks. Then, your revised paper will be judged for final decision of acceptance or rejection.

Thank you

Best Regards,
Tole Sutikno
Editor-in-Chief,
tole@journal.uad.ac.id

TELKOMNIKA (Telecommunication Computing Electronics and Control)
<http://www.journal.uad.ac.id/index.php/TELKOMNIKA>

Editor Subject: [TELKOMNIKA] Editor Decision [DELETE](#)

2018-01-05 03:54 AM
Teguh Firmansyah:

We have reached a decision regarding your submission to TELKOMNIKA (Telecommunication Computing Electronics and Control), "Shunt Active Power Filter based on P-Q Theory with Multilevel Inverters for Harmonic Current Compensation".

Our decision is to: ACCEPT

Assoc. Prof. Dr. Tole Sutikno
Universitas Ahmad Dahlan
tole@journal.uad.ac.id

TELKOMNIKA (Telecommunication Computing Electronics and Control)
<http://www.journal.uad.ac.id/index.php/TELKOMNIKA>

Author Subject: Shunt Active Power Filter based on P-Q Theory with Multilevel Inverters for [DELETE](#)

2018-01-19 11:55 PM

Harmonic Current Compensation

Dear
Dr. Tole Sutikno
Editor-in-Chief, TELKOMNIKA

This mail was attached :

1. Full paper (final revision) of my paper with #6363 [TELKOMNIKA] Shunt Active Power Filter based on P-Q Theory with Multilevel Inverters for Harmonic Current Compensation
2. Payment proof.

Sincerely yours,
Suhendar and Teguh Firmansyah

TELKOMNIKA (Telecommunication Computing Electronics and Control)
<http://www.journal.uad.ac.id/index.php/TELKOMNIKA>

Close

TELKOMNIKA

Telecommunication, Computing, Electronics and Control

ISSN: 1693-6930, e-ISSN: 2302-9293

Accredited First Grade by Ministry of Research, Technology and Higher Education, Republic of Indonesia, Decree No: 21/E/KPT/2018

Scopus
indexed

[HOME](#) [ABOUT](#) [USER HOME](#) [SEARCH](#) [CURRENT](#) [ARCHIVES](#) [ANNOUNCEMENTS](#)
[Home](#) > [User](#) > [Author](#) > [Submissions](#) > #6363 > **Summary**

#6363 Summary

[SUMMARY](#) [REVIEW](#) [EDITING](#)

Submission

Authors	Suhendar Suhendar, Teguh Firmansyah, Alief Maulana, Zuldiag Zuldiag, Vektor Dewanto
Title	Shunt Active Power Filter based on P-Q Theory with Multilevel Inverters for Harmonic Current Compensation
Original file	6363-13722-1-SM.PDF 2017-04-29
Supp. files	None
Submitter	Teguh Firmansyah
Date submitted	April 29, 2017 - 07:37 PM
Section	Power Electronics and Drives
Editor	Pekik Argo Dahono (Review) Yang Han (Review) Shahrin Md Ayob (Review) Nik Rumzi Nik Idris (Review)
Abstract Views	191

Status

Status	Published	Vol 15, No 4: December 2017
Initiated	2018-02-10	
Last modified	2018-08-20	

Submission Metadata

Authors

Name	Suhendar Suhendar
Affiliation	University of Sultan Ageng Tirtayasa, Indonesia
Country	Indonesia
Bio Statement	—
Name	Teguh Firmansyah
ORCID iD	http://orcid.org/0000-0002-9000-9337
Affiliation	University of Sultan Ageng Tirtayasa, Indonesia
Country	Indonesia
Bio Statement	—
Principal contact for editorial correspondence.	
Name	Alief Maulana
Affiliation	University of Sultan Ageng Tirtayasa, Indonesia
Country	Indonesia
Bio Statement	—
Name	Zuldiag Zuldiag
Affiliation	University of Sultan Ageng Tirtayasa, Indonesia
Country	Indonesia
Bio Statement	—
Name	Vektor Dewanto
Affiliation	Bogor Agricultural University, Indonesia
Country	Indonesia
Bio Statement	—

Title and Abstract

Title Shunt Active Power Filter based on P-Q Theory with Multilevel Inverters for Harmonic Current Compensation

Abstract A shunt active power filter based on P-Q theory combined with high pass filters (HPFs) for harmonic-current compensation was proposed in this paper. A dual level H-bridge inverter (DLHI) and clamp diode multilevel inverter (CDMI) as inverters was used. The proposed active power filter was applied to 3-phase power system with 220V voltage and 50Hz frequency. The simulation model was constructed by using Simulink MATLAB. The results show that the proposed active power filter with CDMI produces lower total harmonic distortion (THD) than the active power filters with DLHI. Additionally, the proposed shunt active power filter has lower THD compared with other types of active power filters.

Indexing

Keywords CDMI, DLHI, inverter, simulink MATLAB, THD
Language en

Supporting Agencies

Agencies —

References

References —

TELKOMNIKA Telecommunication, Computing, Electronics and Control

ISSN: 1693-6930, e-ISSN: 2302-9293

Universitas Ahmad Dahlan, 4th Campus, 9th Floor, LPPI Room

Jl. Ringroad Selatan, Kragilan, Tamanan, Banguntapan, Bantul, Yogyakarta, Indonesia 55191

Phone: +62 (274) 563515, 511830, 379418, 371120 ext. 4902, Fax: +62 274 564604

[View TELKOMNIKA Stats](#)

USER

You are logged in as...
teguhfirmansyah

- My Journals
- My Profile
- Log Out

SJR 2018 : 0.283 (Q2)
CiteScore 2018 : 1.09
SNIP 2018 : 0.730

TELKOMNIKA is the best journal in Indonesia 2017

Telkomnika

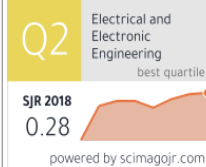

TEMPLATE



QUICK LINKS

- Author Guideline
- Editorial Boards
- Reviewers
- Online Submissions
- Abstracting and Indexing
- Scopus: Add missing document
- Publication Ethics
- Visitor Statistics
- Contact Us

JOURNAL HARDCOPY

Order journal prints (hardcopy)

<<click in here>>

ICW-TELKOMNIKA



AUTHOR

Submissions

- Active (0)
- Archive (2)
- New Submission

JOURNAL CONTENT

Search

Search Scope

All

Browse

- By Issue
- By Author
- By Title
- Other Journals



- HOME
- ABOUT
- USER HOME
- SEARCH
- CURRENT
- ARCHIVES
- ANNOUNCEMENTS

Home > User > Author > Submissions > #6363 > Review

#6363 Review

SUMMARY **REVIEW** EDITING

Submission

Authors	Suhendar Suhendar, Teguh Firmansyah, Alief Maulana, Zuldiag Zuldiag, Vektor Dewanto
Title	Shunt Active Power Filter based on P-Q Theory with Multilevel Inverters for Harmonic Current Compensation
Section	Power Electronics and Drives Pekik Argo Dahono (Review)
Editor	Yang Han (Review) Shahrin Md Ayob (Review) Nik Rumzi Nik Idris (Review)

Peer Review

Round 1

Review Version	6363-13723-1-RV.PDF 2017-04-29
Initiated	2017-05-07
Last modified	2018-04-02
Uploaded file	Reviewer B 6363-22600-1-RV.TXT 2018-04-02

Editor Decision

Decision	Accept Submission 2018-01-05
Notify Editor	Editor/Author Email Record 2018-01-19
Editor Version	None
Author Version	6363-15806-1-ED.DOCX 2017-08-26 DELETE 6363-15806-2-ED.DOCX 2018-01-19 DELETE
Upload Author Version	<input type="button" value="Choose File"/> <input type="button" value="No file chosen"/> <input type="button" value="Upload"/>

TELKOMNIKA Telecommunication, Computing, Electronics and Control
ISSN: 1693-6930, e-ISSN: 2302-9293
Universitas Ahmad Dahlan, 4th Campus, 9th Floor, LPPI Room
Jl. Ringroad Selatan, Kragilan, Tamanan, Banguntapan, Bantul, Yogyakarta, Indonesia 55191
Phone: +62 (274) 563515, 511830, 379418, 371120 ext. 4902, Fax: +62 274 564604

02066049

[View TELKOMNIKA Stats](#)

USER

You are logged in as...
teguhfirmansyah

- My Journals
- My Profile
- Log Out

SJR 2018 : 0.283 (Q2)
CiteScore 2018 : 1.09
SNIP 2018 : 0.730

TELKOMNIKA is the best journal in Indonesia 2017

Telkomnika

Q2 Electrical and Electronic Engineering
best quartile

SJR 2018 0.28

powered by scimagojr.com

TEMPLATE

JOURNAL TEMPLATE

QUICK LINKS

- Author Guideline
- Editorial Boards
- Reviewers
- Online Submissions
- Abstracting and Indexing
- Scopus: Add missing document
- Publication Ethics
- Visitor Statistics
- Contact Us

JOURNAL HARDCOPY

Order journal prints (hardcopy)

< <click in here>>

ICW-TELKOMNIKA

2020 ICW-TELKOMNIKA INTERNATIONAL CONFERENCE

AUTHOR

Submissions

- Active (0)
- Archive (2)
- New Submission

JOURNAL CONTENT

Search

Search Scope
All

Browse

- By Issue
- By Author
- By Title
- Other Journals



- HOME
- ABOUT
- USER HOME
- SEARCH
- CURRENT
- ARCHIVES
- ANNOUNCEMENTS

Home > User > Author > Submissions > #6363 > Editing

#6363 Editing

SUMMARY REVIEW **EDITING**

Submission

Authors Suhendar Suhendar, Teguh Firmansyah, Alief Maulana, Zuldiag Zuldiag, Vektor Dewanto

Title Shunt Active Power Filter based on P-Q Theory with Multilevel Inverters for Harmonic Current Compensation

Section Power Electronics and Drives
Pekik Argo Dahono (Review)

Editor Yang Han (Review)
Shahrin Md Ayob (Review)
Nik Rumzi Nik Idris (Review)

Copyediting

[COPYEDIT INSTRUCTIONS](#)

[REVIEW METADATA](#)

	REQUEST	UNDERWAY	COMPLETE
1. Initial Copyedit File: None	—	—	—
2. Author Copyedit File: None <input type="button" value="Choose File"/> No file chosen <input type="button" value="Upload"/>	—	—	
3. Final Copyedit File: None	—	—	—

Copyedit Comments No Comments

Layout

Galley Format	FILE		
1. PDF VIEW PROOF	6363-26602-1-PP.PDF	2018-08-09	275
Supplementary Files	FILE	None	

Layout Comments No Comments

Proofreading

[REVIEW METADATA](#)

	REQUEST	UNDERWAY	COMPLETE
1. Author	—	—	
2. Proofreader	—	—	—
3. Layout Editor	—	—	—

Proofreading Corrections No Comments [PROOFING INSTRUCTIONS](#)

TELKOMNIKA Telecommunication, Computing, Electronics and Control
ISSN: 1693-6930, e-ISSN: 2302-9293
Universitas Ahmad Dahlan, 4th Campus, 9th Floor, LPPI Room
Jl. Ringroad Selatan, Kragilan, Tamanan, Banguntapan, Bantul, Yogyakarta, Indonesia 55191
Phone: +62 (274) 563515, 511830, 379418, 371120 ext. 4902, Fax: +62 274 564604

02086052

[View TELKOMNIKA Stats](#)

USER

You are logged in as...
teguhfirmansyah

- My Journals
- My Profile
- Log Out

SJR 2018 : 0.283 (Q2)
CiteScore 2018 : 1.09
SNIP 2018 : 0.730

TELKOMNIKA is the best journal in Indonesia 2017

Telkomnika



TEMPLATE



QUICK LINKS

- Author Guideline
- Editorial Boards
- Reviewers
- Online Submissions
- Abstracting and Indexing
- Scopus: Add missing document
- Publication Ethics
- Visitor Statistics
- Contact Us

JOURNAL HARDCOPY

Order journal prints (hardcopy)
< <click in here> >

ICW-TELKOMNIKA



AUTHOR

- Submissions**
- Active (0)
 - Archive (2)
 - New Submission

JOURNAL CONTENT

Search

Search Scope
All

- Browse**
- By Issue
 - By Author
 - By Title
 - Other Journals

Shunt Active Power Filter based on P-Q Theory with Multilevel Inverters for Harmonic Current Compensation

Suhendar¹, Teguh Firmansyah^{1*}, Alief Maulana¹, Zuldiag¹, Vektor Dewanto²

¹Department of Electrical Engineering, University of Sultan Ageng Tirtayasa, Cilegon 42435.

²Computer Science Department, Bogor Agricultural University, Bogor.

*Corresponding author, e-mail: teguhfirmansyah@untirta.ac.id

Abstract

A shunt active power filter based on P-Q theory combined with high pass filters (HPFs) for harmonic-current compensation was proposed in this paper. A dual level H-bridge inverter (DLHI) and clamp diode multilevel inverter (CDMI) as inverters was used. The proposed active power filter was applied to 3-phase power system with 220V voltage and 50Hz frequency. The simulation model was constructed by using Simulink MATLAB. The results show that the proposed active power filter with CDMI produces lower total harmonic distortion (THD) than the active power filters with DLHI. Additionally, the proposed shunt active power filter has lower THD compared with other types of active power filters.

Keywords: CDMI, DLHI, Inverter, Simulink MATLAB, THD

1. Introduction

The power quality is determined by voltage swell, voltage sag, flicker, voltage interruption, negative and zero sequence components, voltage and current harmonics [1],[2]. The use of non-linear load can increase a harmonic current [3]. The harmonic current also cannot contribute to the active power and need to be eliminated to enhance the power quality [4]. Recent efforts have been made to improve the power quality by reducing harmonic current based on active power filters [5]. A three-phase active power filters was proposed by [6]. This active power filter is controlled by the P-Q theory, the notch instantaneous method, and the positive sequence method. A pulse width modulation (PWM) was used as an inverter. This research shows that a notch instantaneous method can reduce a harmonic current with the value of total harmonic distortion (THD) from 19.76 % down to 5.58 %. Furthermore, a positive sequence method can reduce THD to 12.76 %, THD depression does not occur significantly. Compared with the previous methods, the P-Q theory can reduce THD to 3.54 %. The THD result is lower than those of the notch instantaneous and positive sequence methods.

A single-phase shunt active filter with a fuzzy controller and a PI controller for harmonic mitigation was proposed by [7]. This active power filter was applied to 230 V, and 50 Hz power systems. The fuzzy controller was reduced THD significantly in comparison with a conventional PI controllers. The dual-level inverter with a PI controller has THD of 8.39 %, which is higher than dual-level inverter with a fuzzy controller with THD of 5.68 %. In the case of a multi-level inverter, the PI controller has 7.10 % and it is also higher than multilevel inverter with a fuzzy controller with THD 4.47 %. Ref [8] proposed a 3-level (NPC) shunt active power filter based on P-Q theory combined with a fuzzy controller for harmonic-current compensation. The simulation results show that the effectiveness of the designed shunt active filter based on PWM fuzzy logic controllers. THD is reduced after compensation to 2.12 %.

In this paper, we propose a shunt active power filter based on P-Q theory combined with high pass filters (HPFs) for harmonic-current compensation. In this research, we used a dual level H-bridge inverter (DLHI) and clamp diode multilevel inverter (CDMI) as the inverters. We applied the proposed active power filter to 3-phase 220 V and 50 Hz power systems. The superiority of P-Q theory includes the capability of working instantaneously and in time domain [9], [10], [11]. The P-Q theory is applied in 3-phase [12]. Hence, P-Q theory considers the 3-phase as a unit, not a superposition or sum of three single-phase circuits [13]. Therefore, the P-Q theory is flexible in designing shunt active power filters combined with a multilevel inverter for harmonic-current compensation. The design methodology is detailed in the following sections.

Section 1 describes the state of the art solutions. Section 2 describes the P-Q theory instantaneous power. Furthermore, the performance of the proposed shunt active power filter is reported in Section 3. Finally, Section 4 concludes this research.

2. Research Method

As shown in Figure 1, we propose a shunt active power filter based on P-Q theory combined with high pass filters (HPFs) for harmonic-current compensation. We applied the proposed active power filter to 3-phase power system with a voltage of 220 V and frequency of 50 Hz. A flow chart for calculation of compensating current shown in Figure 2. A system with nonlinear load was constructed using Simulink MATLAB.

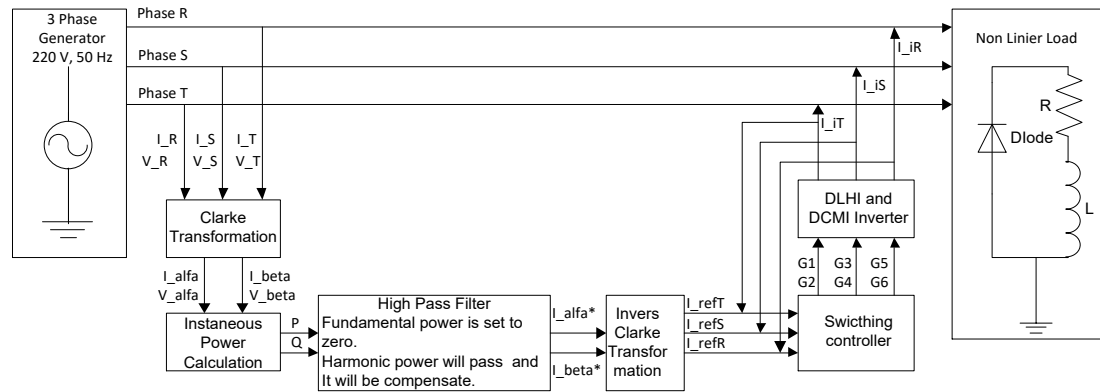

Figure 1. Proposed a shunt active power filter with CDMI and DLHI inverter

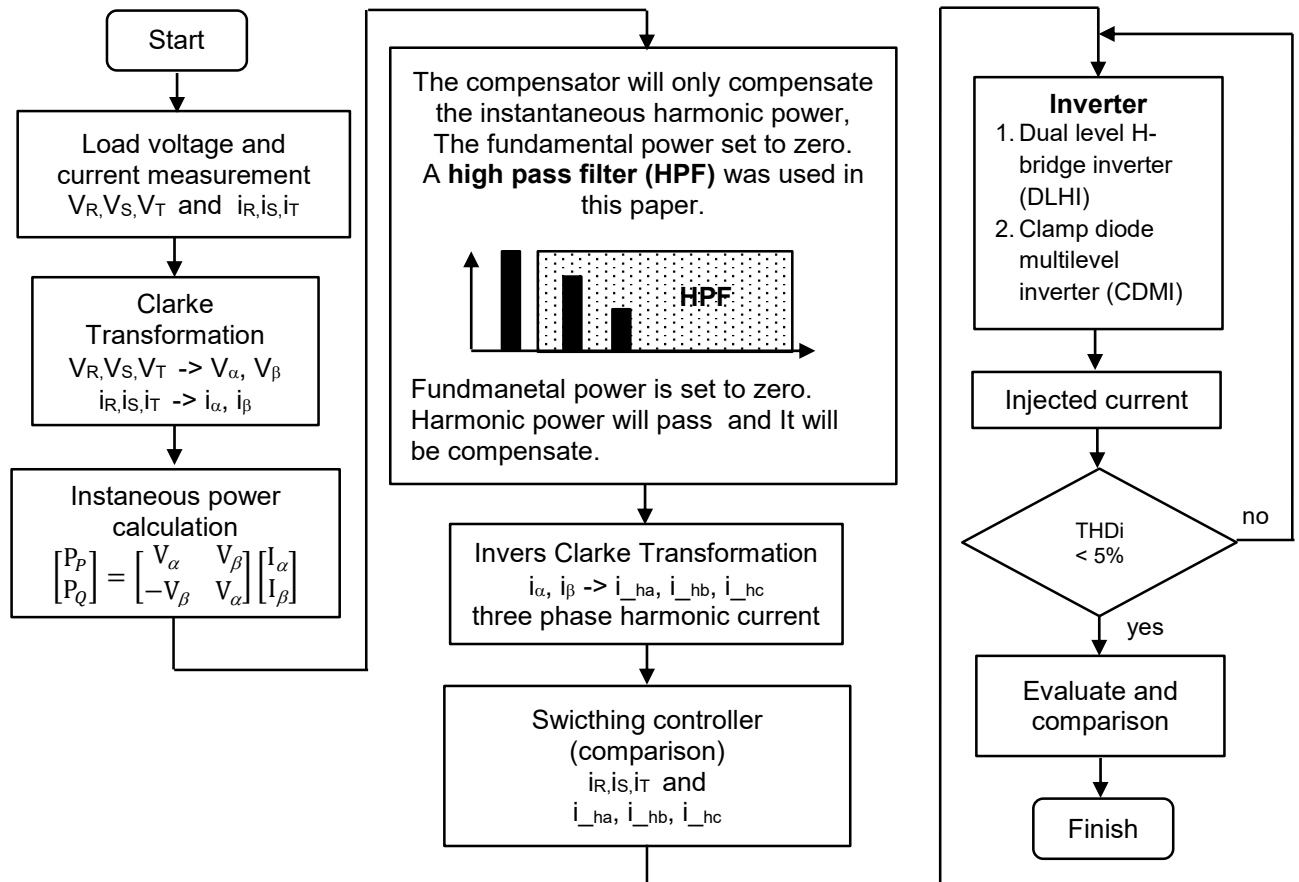

Figure 2. A flow chart for calculation of compensating current

According to IEEE-519 standard, the total harmonic distortion (THD) is given by [18]:

$$THD = \frac{\sqrt{\sum_{h=2}^{\infty} I_{hRMS}^2}}{I_{RMS}} \tag{1}$$

where I_{RMS} is the effective value of fundamental current and I_{hRMS} is the effective value of harmonic current. Filter is not only reduce interference but also reduce harmonics power [14], [15], [16], [17]. To reduce the THD, this study was used the P-Q theory. The P-Q instantaneous power theory was introduced by Akagi, et al [13], [18]. The P-Q theory consists of Clark Transformation as shown in Figure 2. The three-phase current of I_R, I_S, I_T and voltage V_R, V_S, V_T in R-S-T coordinates transform to α - β coordinates using Equation (2) and (3) [18].

$$\begin{bmatrix} I_{\alpha} \\ I_{\beta} \end{bmatrix} = \sqrt{\frac{2}{3}} \begin{bmatrix} 1 & -\frac{1}{2} & \frac{1}{2} \\ 0 & \frac{\sqrt{3}}{2} & -\frac{\sqrt{3}}{2} \end{bmatrix} \begin{bmatrix} I_R \\ I_S \\ I_T \end{bmatrix} \tag{2}$$

$$\begin{bmatrix} V_{\alpha} \\ V_{\beta} \end{bmatrix} = \sqrt{\frac{2}{3}} \begin{bmatrix} 1 & -\frac{1}{2} & \frac{1}{2} \\ 0 & \frac{\sqrt{3}}{2} & -\frac{\sqrt{3}}{2} \end{bmatrix} \begin{bmatrix} V_R \\ V_S \\ V_T \end{bmatrix} \tag{3}$$

After the Clarke transformation of current and voltage. It's followed by instaneous power calculation. Real power and reactive powers are calculated with (4):

$$\begin{bmatrix} P \\ Q \end{bmatrix} = \begin{bmatrix} V_{\alpha} & V_{\beta} \\ -V_{\beta} & V_{\alpha} \end{bmatrix} \begin{bmatrix} I_{\alpha} \\ I_{\beta} \end{bmatrix} \tag{4}$$

Thus:

$$P = \bar{P} + \tilde{P}$$

$$Q = \bar{Q} + \tilde{Q}$$

where

\bar{P} =instantaneous real power P due to the fundamental component;

\tilde{P} =instantaneous harmonic real power P due to the harmonic component;

\bar{Q} =instantaneous reactive power Q due to the fundamental component;

\tilde{Q} =instantaneous harmonic reactive power Q due to the harmonic component;

In this paper, a high pass filter (HPF) was used. The real power is set to zero and an instantaneous reactive power is set into opposite vectors in order to cancel the reactive component of the line current. The compensator will only compensate the instantaneous reactive power.

$$\begin{bmatrix} I_{c\alpha} \\ I_{c\beta} \end{bmatrix} = \frac{1}{V_{\alpha}^2 + V_{\beta}^2} \begin{bmatrix} V_{\alpha} & V_{\beta} \\ V_{\beta} & -V_{\alpha} \end{bmatrix}^{-1} \begin{bmatrix} -\tilde{P} \\ -\tilde{Q} \end{bmatrix} \tag{5}$$

To get the reference current harmonics, the harmonic currents in the bi-phase system to be transformed by Inverse Clarke Transformation of α - β , which is given by Equation (6) [13], [18]

$$\begin{bmatrix} I_{ha} \\ I_{hb} \\ I_{hc} \end{bmatrix} = \sqrt{\frac{2}{3}} \begin{bmatrix} 1 & 0 \\ -\frac{1}{2} & \frac{\sqrt{3}}{2} \\ -\frac{1}{2} & -\frac{\sqrt{3}}{2} \end{bmatrix} \begin{bmatrix} I_{c\alpha} \\ I_{c\beta} \end{bmatrix} \tag{6}$$

The controller is used for generating pulses as the input of the inverter by comparing the value of the reference current and the current measured.

Table 2. Parameter of shunt active power filter simulation

Parameter	Value
Power system	Three Phase
Vs	220 V
Frequency	50 Hz
Rl	100 Ω
Ll	5 H
Rf	10 Ω
Lf	5 H

Table 3. The comparing reference current and the current measured.

Condition	State	
	G1	G2
$I_{ha} \geq I_R$	1	0
$I_{ha} < I_R$	0	1
Condition	State	
	G1	G2
$I_{hb} \geq I_S$	1	0
$I_{hb} < I_S$	0	1
Condition	State	
	G1	G2
$I_{hc} \geq I_T$	1	0
$I_{hc} < I_T$	0	1

The last circuit is an inverter. Figure 3 and Figure 4 show the MATLAB simulation of dual level H-bridge inverter (DLHI) dan clamp diode multilevel inverter (CDMI), respectively. Table 2 shows the parameter of simulation and Table 3 shows the comparing reference current and the current measured.

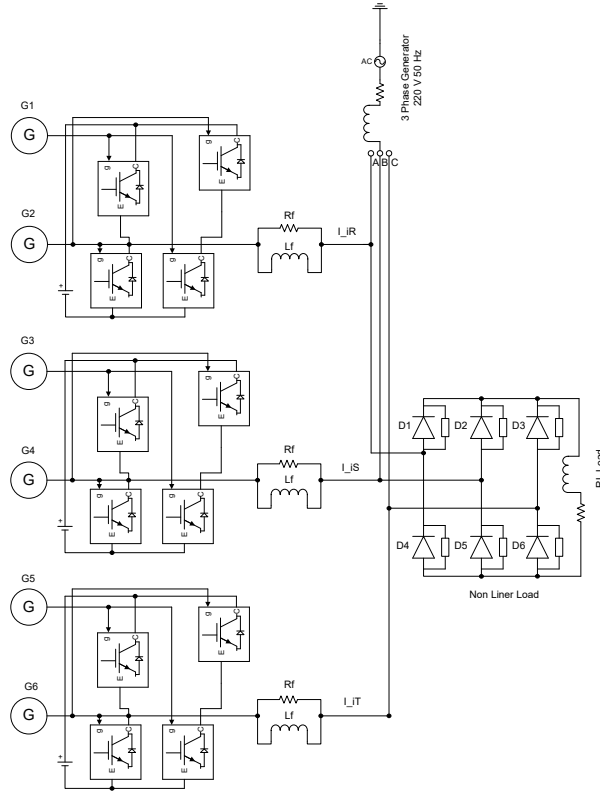

Figure 3. Dual level H-bridge inverter (DLHI) [This Research: Inverter Model 1]

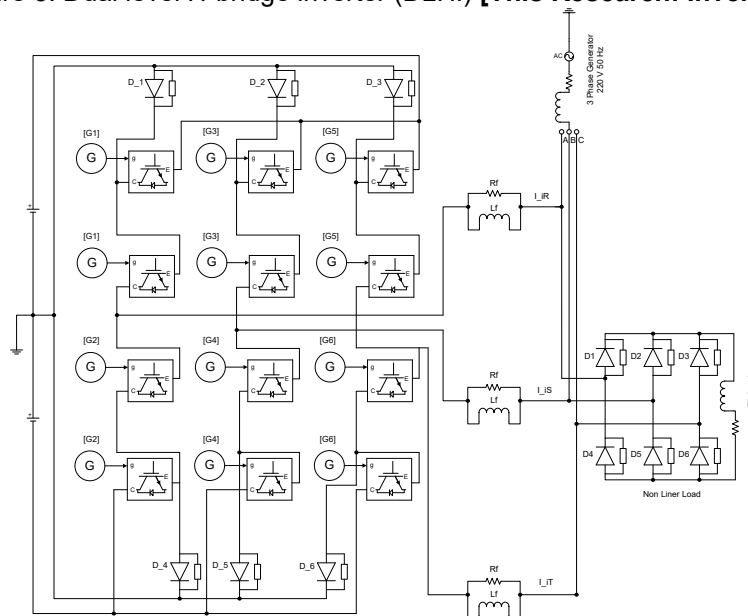

Figure 4. Clamp diode multilevel inverter (CDMI) [This Research: Inverter Model 2]

3. Result and Analysis

The performances of the proposed shunt active power were explained in this section. Section 3.1 shows the performance of three-phase power system with nonlinear load without an

active filter. Furthermore, section 3.2 and section 3.3 was explained shunt active power filter with dual level H-bridge inverter (DLHI) and clamp diode multilevel inverter (CDMI), respectively.

3.1. Performance the three phase power system with nonlinear load

A system with nonlinear load as shown in Figure 3, and the THD before the shunt active filter operation has 28.41 %, 27.08 %, and 28.35 % for phase R, phase S, and phase T, respectively. It is shown that a nonlinear load was effected to increase the THD value.

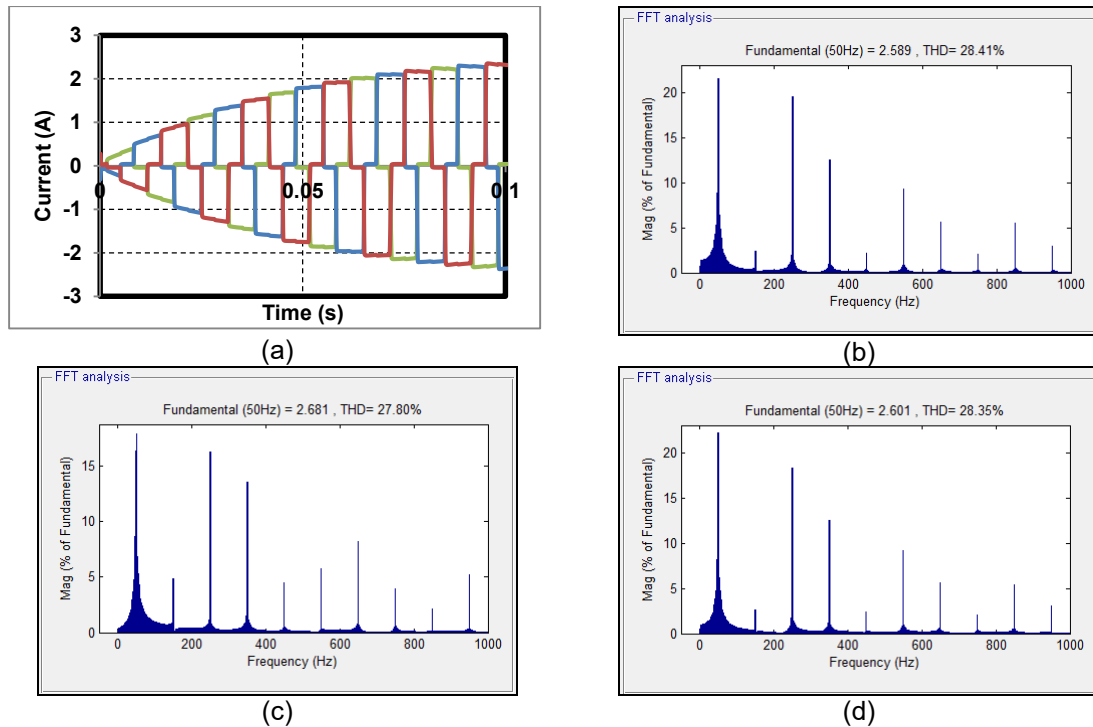

Figure 5. A system before the shunt active filter operation (a) Three phase current, (b) Total harmonic distortion phase R (I_R), (c) Total harmonic distortion phase S (I_S), (d) Total harmonic distortion phase T (I_T)

Figure 5a. shows a three phases of current in transient condition and steady state condition. At the steady state condition, the Fourier Series approximations of I_R current is shown in Figure 6 and the Equation of I_R is given by:

$$I_R = 2.6 \sin(\omega t) + 0.07 \sin(3\omega t + 230^\circ) + 0.55 \sin(5\omega t + 145^\circ) + 0.33 \sin(7\omega t + 56.4^\circ) + 0.06 \sin(9\omega t + 163.7^\circ)$$

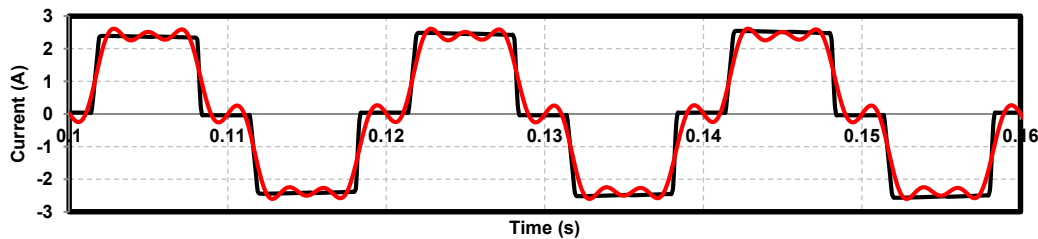

Figure 6. The Fourier Series approximations of I_R current

The FFT analysis shows that the three phases system has large a total harmonic distortion (THD) and the time domain plot also agrees with Fourier Series approximations. The Fourier Series approximations shows that the three phases system has a lot of harmonic frequency. This paper was proposed a shunt active power filter based on P-Q theory. As an inverter, a dual level H-bridge inverter (DLHI) and clamp diode multilevel inverter (CDMI) was used in this research.

3.2. Performance Shunt Active Filter with dual level H-bridge inverter (DLHI)

The performance shunt active filter with dual level H-bridge inverter (DLHI) is shown in Figure 7. It is shown that before the shunt active filter operation, the source of current is highly rich in harmonics. After the shunt active filter starts the compensation process, the source is sinusoidal with phase 0°, 120°, and 240°. A Powergui FFT Analysis Tools on Powergui Matlab Simulink is used to get the value of THD. The THD before the shunt active filter operation has 28.41 %, 27.08 %, and 28.35 %. The THD after the shunt active filter with dual level H-bridge inverter (DLHI) has 3.73 %, 3.72 %, and 4.53 %. The THD value has conformity with the standard IEEE recommendations (THD <=5%). Table 4 shows the THD after and before harmonic currents compensation with inverter dual level H-bridge inverter (DLHI)

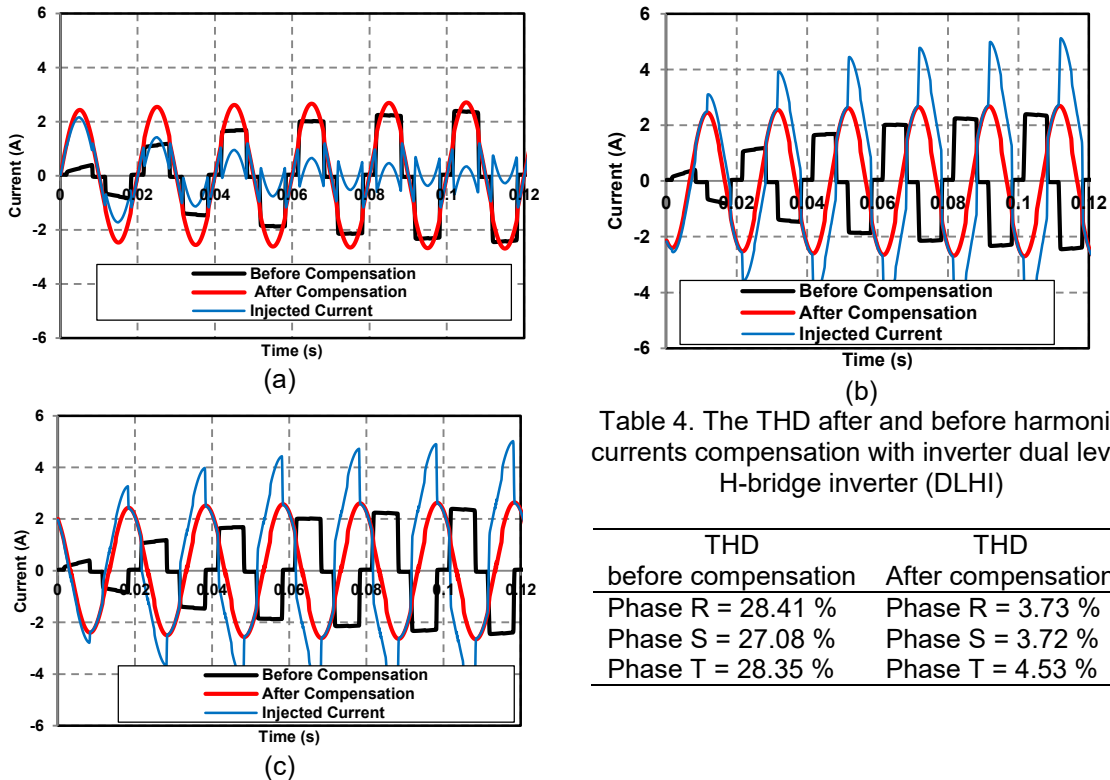

Table 4. The THD after and before harmonic currents compensation with inverter dual level H-bridge inverter (DLHI)

THD before compensation	THD After compensation
Phase R = 28.41 %	Phase R = 3.73 %
Phase S = 27.08 %	Phase S = 3.72 %
Phase T = 28.35 %	Phase T = 4.53 %

Figure 7. (a) The source current (I_R) after and before compensation with injected current by dual level H-bridge inverter (DLHI), (b) The source current (I_S) after and before compensation with injected current by dual level H-bridge inverter (DLHI), (c) The source current (I_T) after and before compensation with injected current by dual level H-bridge inverter (DLHI)

3.3. Performance Shunt Active Filter with clamp diode multilevel inverter (CDMI)

The performance shunt active filter with a clamp diode multilevel inverter (CDMI) is shown in Figure 8. It is shown that before the shunt active filter operation, the source of current is highly rich in harmonics. After the shunt active filter starts the compensation process, the source is sinusoidal with phase 0°, 120°, and 240°. The THD after the shunt active filter with clamp diode multilevel inverter (CDMI) has 1.91 %, 1.93 %, and 1.91 % as shown in Table 5. The THD value has conformity with the standard IEEE recommendations (THD <=5%).

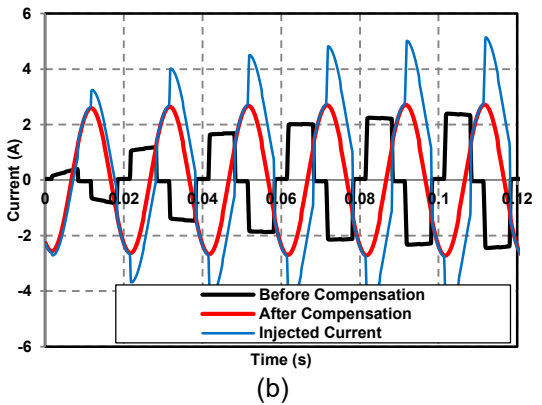
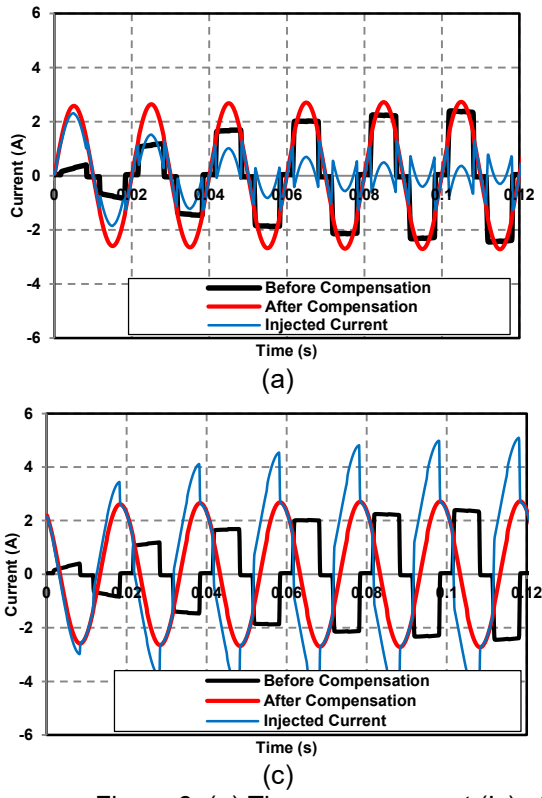

Table 5. The THD after and before harmonic currents compensation with inverter dual level H-bridge inverter (DLHI)

	THD before compensation	THD After compensation
Phase R =	28.41 %	1.91 %
Phase S =	27.08 %	1.93 %
Phase T =	28.35 %	1.91 %

Figure 8. (a) The source current (I_R) after and before compensation with injected current by clamp diode multilevel inverter (CDMI), (b) The source current (I_S) after and before compensation with injected current by clamp diode multilevel inverter (CDMI), (c) The source current (I_T) after and before compensation with injected current by clamp diode multilevel inverter (CDMI)

The result showed that active power filter with CDMI produced lower total harmonic distortion (THD) than active power filter with DLHI. The THD with DLHI and CDMI is lower than limits of IEEE harmonics standards. It is also shown that the proposed shunt active power filter has lower THD compared to another type of active power filter as shown in Table 6.

Table 6. The THD value compared to another type of active power filter

References	Systems	Controller	Inverter	THD before compensation	THD after compensation
Ciprian Balanuta, et al [6]	3-phase 300 V 50 Hz	Notch control	pulse width modulation	19.76 %	5.58 %
		P-Q Theory		19.76 %	3.54 %
		Positive Sequences		19.76 %	12.76 %
C L Anooja [7]	1-phase 230 V 50 Hz	PI controller	dual-level inverter	15.5 %	8.39 %
		Fuzzy controller	multi-level inverter	15.5 %	7.10 %
			dual-level inverter	15.5 %	5.68 %
			multi-level inverter	15.5 %	4.47 %
Chennai Salim [8]	3-phase 220V 50 Hz	Fuzzy controller	pulse width modulation	28.16 %	2.12 %
This work	3-phase 220 V 50 Hz	P-Q Theory combine HPF	dual level H-bridge inverter (DLHI)	Phase R = 28.41 % Phase S = 27.08 % Phase T = 28.35 %	Phase R = 3.73 % Phase S = 3.72 % Phase T = 4.53 %
			clamp diode multilevel inverter (CDMI)	Phase R = 28.41 % Phase S = 27.08 % Phase T = 28.35 %	Phase R = 1.91 % Phase S = 1.93 % Phase T = 1.91 %

4. Conclusion

A shunt active power filter based on P-Q theory with dual level H-bridge inverter (DLHI) and clamp diode multilevel inverter (CDMI) was design, modified, and analyzed. This shunt active power filter was applied to 3 phase power system with a voltage of 220 V and frequency of 50 Hz. The simulation model was constructed using Simulink MATLAB. The simulation result showed that active power filter with CDMI produced lower total harmonic distortion (THD) than active power filter with DLHI. The two cases studied in conformity with the standard IEEE recommendations (THD $\leq 5\%$). It is also shown that the proposed shunt active power filter has lower THD compared to another type of active power filter.

References

- [1] Ahuja, Rajesh Kr Chauhan, Aasha. Hysteresis Control for Current Harmonics Suppression Using Shunt Active Filter. *International Journal of Advancements in Research and Technology (IJART)*. 2012; 1(6): 17-24.
- [2] Akagi H. New Trends in Active Filters for Power Conditioning. *IEEE Transaction on Industrial Applications*. 1996; 32(4): 1312-1322.
- [3] O, Abdelkhalek. A Novel Theory Of Reference Harmonic Current Identification Based On The Per Unit System Used For The Active Filters. *Journal of Electrical & Electronics Engineering (JEEE)*. 2008; 8(2): 747-757.
- [4] Ciprian Balanuta, Gelu Gurguiatu. Three-Phase Active Power Filter Control Using Notch Instantaneous P-Q Theory And Positive Sequence Method. *Scientific Bulletin of the Electrical Engineering (SBEE)*. 2011; 3(17): 11-17.
- [5] Karuppanan Pitchai Vijaya. Adaptive-Fuzzy Controller Based Shunt Active Filter for Power Line Conditioners. *TELKOMUNIKA*. 2014; 9(2): 203-210.
- [6] S.Narmada. Simulink Model of Elimination of Harmonics By Using Multilevel - Inverters Through Hysteresis Control. *International Journal of Advanced Trends in Computer Science and Engineering (IJATCSE)*. 2013; 2(1): 286 – 292.
- [7] C L Anooja, N Leena. Single Phase Shunt Active Filter with Fuzzy Controller for Harmonic Mitigation. *International Journal of Scientific & Engineering Research (IJSER)*. 2013; 4(9): 445-451.
- [8] Chennai Salim, Benchouia Mohamed Toufik. Fuzzy Controller for Harmonic Currents Compensation under Non-Ideal Voltage Conditions. *International Journal on Electrical Engineering and Informatics (IJEI)*. 2014; 6(2); 342-358.
- [9] Krishna Veer Singh, Priyank Bhavsar. Matlab Simulation of Single Phase Shunt Active Filter Based on PQ Theory. *International Journal of Advances in Electrical and Electronics Engineering (IJAEEE)*. 2012; 2(3): 349-357.
- [10] Himabindu, T., 2012. Performance Of Single Phase Shunt Active Filter Based On P-Q Technique Using Matlab/Simulink. *International Journal of Engineering Research & Technology (IJERT)*. Volume 1(9), pp. 1-5
- [11] G, Vijayakumar. R, Anita. Real time digital simulation of shunt active filter for mitigation of current harmonics with P-Q theory. *Scientific Research and Essays (SRE)*. 2013; 8(26): 1239-1251.
- [12] Priyank Rameshbhai Bhavsar. Pinkal J. Patel. *Shunt Active Filter : PSIM based Simulation and analysis using P-Q theory*. Proc. of the International Conference on Science and Engineering (ICSE), 2011: 90-93.
- [13] Pradeep Kumar. Simulation of Three-Phase Three-Wire Active Power Filter using p-q Theory. *International Journal Of Innovative Research In Electrical, Electronics, Instrumentation And Control Engineering (IJIREEICE)*. 2016; 4(3): 5-8.
- [14] W, Gunawan. et al. Design of triple-band bandpass filter using cascade tri-section stepped impedance resonators. *Journal of ICT Research and Applications*. 2016; 10: 43-56.
- [15] W. Gunawan, et al. Multiband bandpass filter (BPF) based on folded dual crossed open stubs. *International Journal of Technology*. 2014; 5: 32-39.
- [16] F. Teguh, et al. Multiband RF low noise amplifier (LNA) base on multi section impedance transformer for multi frequency application. *International Journal of Applied Engineering Research*. 2016; 11: 3478-3483.

- [17] G. Wibisono and T. Firmansyah. *Design of dielectric resonators oscillator for mobile WiMAX at 2,3 GHz with additional coupling $\lambda/4$* . IEEE Region 10 Conference TENCON. 2011: 489-493
- [18] M, Priya. Uthaya, Suresh Balu. Simulation Results Of A Shunt Active Power Filter Using P-Q Theory Power Components Calculations. *International Journal of Advance Research in Computer Science and Management Studies (IJARCSMS)*. 2014; 2(2): 250-254.