

LAMPIRAN

Standard Operating Procedure (SOP)

Kode SOP : ASK-001
Ruang Lingkup : Pengoperasian dan Pengujian Nilai Sudut
Unit/Pelaksana : Operator ASK
Dokumen Terkait : -
Dibuat Tanggal : 11/2022

Tujuan:

Memastikan pengoperasian dan pengujian nilai alat sudut kontak terlaksana secara optimal sehingga mendapat hasil yang baik.

Daftar Istilah:

ASK : Alat Sudut Kontak
LB – ADSA : Menentukan bentuk sifat cairan hidrofili atau hidropobik.
Imagej : *Software* yang digunakan untuk menganalisa foto dan menentukan sudut.

Prosedur:

I. Tahap Persiapan Alat dan Bahan

1. Menyiapkan Handphone
2. Menyiapkan Tripod
3. Menyiapkan Benda Uji seperti : *Aluminium, Kaca, Mild Steel, Galvalum, Akrilik, dan Styrofoam.*
4. Menyiapkan Cairan seperti : Air, Aquades, Hexadekana, garam, dan cuka.

5. Menyiapkan alat sudut kontak.

II. Tahap Pengujian

1. Sambungkan aliran daya listrik untuk menghidupkan lampu led
2. Memasang tripod dan memasang handphone pada tripod
3. Mengatur kamera untuk mendapatkan *angle* yang tepat pada zoom 6.0x megapixels
4. Menaruh benda uji pada permukaan sliding.
5. Memutar berlawanan searah jarum jam untuk memajukan sliding dengan jarak 9 mm dan mengatur ketinggian benda uji dengan jarak minimum 140 mm hingga jarak maksimum 180 mm.
6. Mengatur mikropipet
7. Memasukan alat mikropipet ke lubang penutup atas untuk meneteskan cairan ke benda uji
8. Memulai merekam video
9. Meneteskan air ke permukaan benda uji dengan jarak 15 mm.
10. menekan tombol stop pada handphone.
11. Memutar searah jarum jam sampai alat sliding ke posisi awal.
12. Mengambil benda uji dan membersihkan
13. Selesai

III. Tahap Pengolahan Data

1. Download Software *Imagej*
2. Pastikan computer/PC sudah terinstal *software imagej* untuk mendapatkan nilai sudut.
3. Buka Software *Imagej*

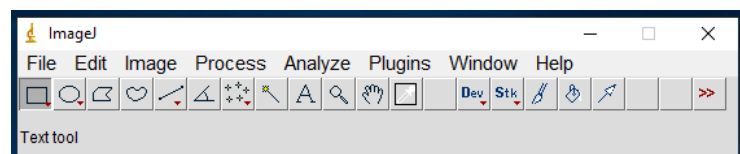

Gambar 1 Menu Utama Software *Imagej*

4. Memilih foto dari data video saat tetesan air jatuh ke permukaan benda uji untuk menganalisa.
5. Klik file kemudian pilih open. Pilih file atau gambar yang ingin kita cari sudutnya

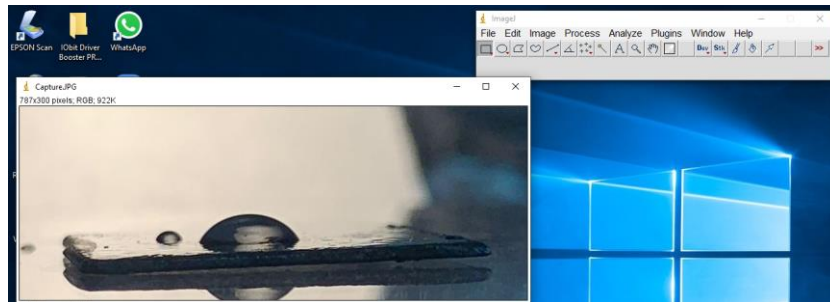

Gambar 2 Memasukan Gambar pada *Software*

6. Setelah sudah memilih file atau gambar. Klik *image* kemudian pilih type selanjutnya pilih 32-bit

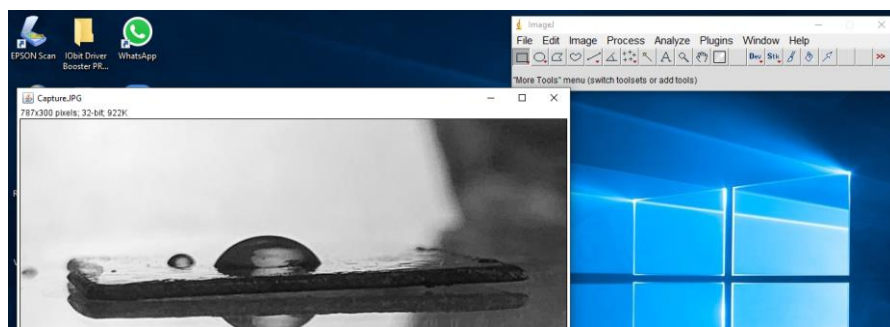

Gambar 3 Merubah Tipe 32-Bit

7. Kemudian klik plugins. Setelah itu klik pilih drop analysis kemudian pilih *drop analysis – LB-ADSA*

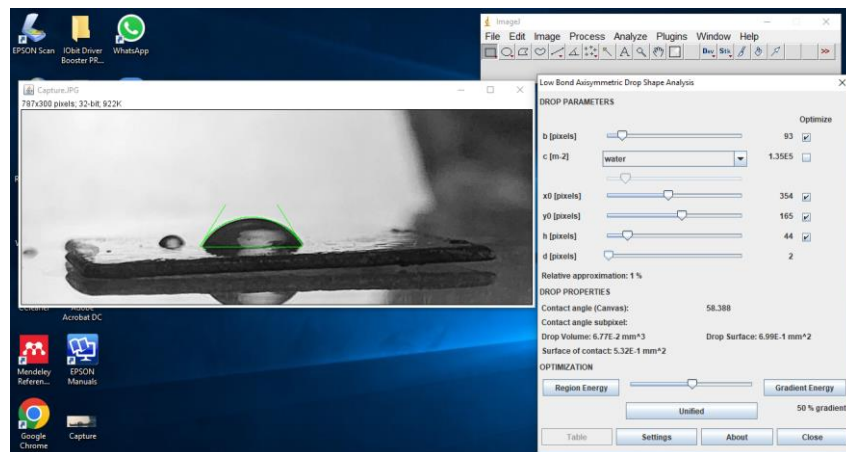

Gambar 4 Mencari Nilai Sudut

8. Pilih cairan yang digunakan dalam penelitian.
9. Mengatur sumbu x,y,h dan b. hingga mendapatkan nilai sudut kontak
10. Selesai



Tahap 1 Persiapan bagian – bagian alat



Tahap 2 Pemasangan *Sliding Nut* pada batang Aluminium



Tahap 3 Pemasangan siku pada batang



Tahap 4 Pemasangan bantalan pada alat ukur sudut kontak



Tahap 5 Pemasangan roda *bearing*



Tahap 6 Pemasangan rumah untuk *sliding* pada poros ulir



Tahap 7 Penggabungan alas permukaan benda uji



Tahap 9 Pemasangan *flange bearing* dan poros ulir



Tahap 10 Tampak depan alat ukur sudut kontak



Tahap 11 Tampak atas Alat Sudut Kontak

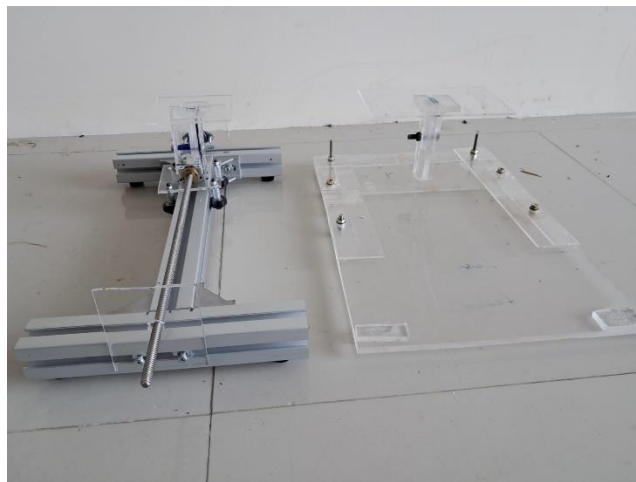

Tahap 13 membandingkan Alat Sudut Kontak sebelum dan sesudah modifikasi

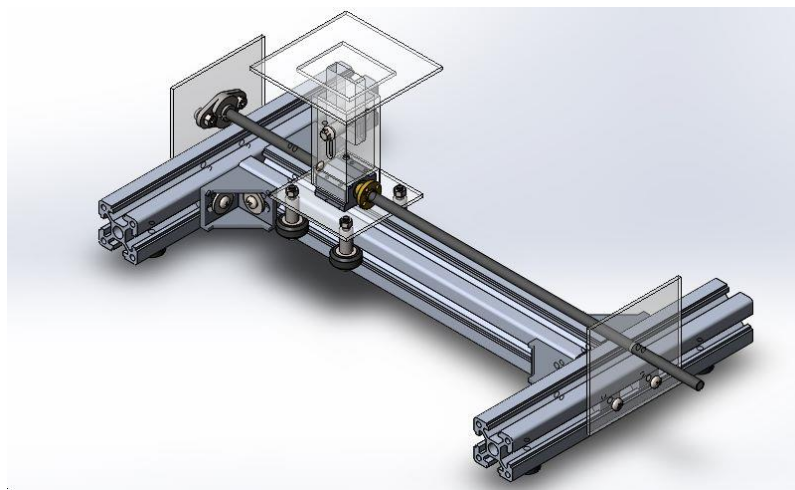

Gambar *Solidworks* Alat Ukur Sudut Kontak

Pengujian

Solid	Liquid	I	II	III	Results			Y _{liquid}
Galvalum	Air	50,5	48,9	50,5	50,0	±	0,9	72,8
	Garam	44,1	43,5	44,1	43,9	±	0,3	75
	Aquades	40,4	41,8	40,4	40,9	±	0,8	72,8
	hexadecane	30,5	30,2	30,5	30,4	±	0,2	27,4
	Cuka	70,3	70,3	73,8	71,5	±	2,0	55
Aluminium	Air	61,4	67,2	64	64,2	±	2,9	72,8
	Garam	59,9	62	62	61,3	±	1,2	75
	Aquades	60,9	61,4	61,4	61,2	±	0,3	72,8
	hexadecane	23,3	22,2	23,6	23,0	±	0,7	27,4
	Cuka	97,3	92,1	97,3	95,6	±	3,0	55
Mild Steel	Air	69,6	72,7	69,6	70,6	±	1,8	72,8
	Garam	73,8	76,7	76,7	75,7	±	1,7	75
	Aquades	41,8	43,7	43,7	43,1	±	1,1	72,8
	hexadecane	22,2	21	22,2	21,8	±	0,7	27,4
	Cuka	54,4	55,8	55,8	55,3	±	0,8	55
Styrofoam	Air	41,4	40,5	44,9	42,3	±	2,3	72,8
	Garam	66,9	66,8	69,6	67,8	±	1,6	75
	Aquades	66,9	69,5	66,9	67,8	±	1,5	72,8
	hexadecane	22,8	27,7	27,7	26,1	±	2,8	27,4
	Cuka	66,9	60,6	63	63,5	±	3,2	55
Akrilik	Air	80,5	82,7	82,7	82,0	±	1,3	72,8
	Garam	67,4	68,9	69,6	68,6	±	1,1	75
	Aquades	73,7	75,1	71	73,3	±	2,1	72,8
	hexadecane	45,1	45,9	46,8	45,9	±	0,9	27,4
	Cuka	64	61,4	61,4	62,3	±	1,5	55
kaca (literatur)	air	109,6	110,2	111,3	110,4	±	0,9	72,8
	formamide	88,6	90,3	92,2	90,4	±	1,8	58,2
	hexadecane	39,4	40,7	41,8	40,6	±	1,2	27,4
Kaca	undecane	26,5	27,3	27,9	27,2	±	0,7	24,66
	octane	9,4	9,8	10,8	10,0	±	0,7	21,6
Kaca	Air	56,2	56,2	59,5	57,3	±	1,9	72,8
	Garam	51,5	48,9	48,9	49,8	±	1,5	75
	Aquades	55,1	56,2	55,1	55,5	±	0,6	72,8
	hexadecane	34,9	40	35,3	36,7	±	2,8	27,4
	Cuka	59,5	56,2	59,5	58,4	±	1,9	55

angle, rad	cos θ	(1+ cos θ)/2	square	V_{soliid}
0,9	0,6	0,8	0,7	49,1
0,8	0,7	0,9	0,7	55,5
0,7	0,8	0,9	0,8	56,1
0,5	0,9	0,9	0,9	23,8
1,2	0,3	0,7	0,4	23,9
1,1	0,4	0,7	0,5	37,5
1,1	0,5	0,7	0,5	41,1
1,1	0,5	0,7	0,5	39,9
0,4	0,9	1,0	0,9	25,3
1,7	-0,1	0,5	0,2	11,2
1,2	0,3	0,7	0,4	32,3
1,3	0,2	0,6	0,4	29,1
0,8	0,7	0,9	0,7	54,5
0,4	0,9	1,0	0,9	25,5
1,0	0,6	0,8	0,6	33,8
0,7	0,7	0,9	0,8	55,1
1,2	0,4	0,7	0,5	35,6
1,2	0,4	0,7	0,5	34,6
0,5	0,9	0,9	0,9	24,7
1,1	0,4	0,7	0,5	28,8
1,4	0,1	0,6	0,3	23,6
1,2	0,4	0,7	0,5	34,9
1,3	0,3	0,6	0,4	30,2
0,8	0,7	0,8	0,7	19,7
1,1	0,5	0,7	0,5	29,5
1,9	-0,3	0,3	0,1	7,7
1,6	0,0	0,5	0,2	14,4
0,7	0,8	0,9	0,8	21,2
0,5	0,9	0,9	0,9	22,0
0,2	1,0	1,0	1,0	21,3
1,0	0,5	0,8	0,6	43,2
0,9	0,6	0,8	0,7	50,8
1,0	0,6	0,8	0,6	44,7
0,6	0,8	0,9	0,8	22,2
1,0	0,5	0,8	0,6	31,9



Gambar Bahan *Aluminium*



Gambar Bahan *Galvalum*



Gambar Bahan *Mild Steel*



Gambar Bahan *Styrofoam*



Gambar Cairan Cuka



Garam Cairan Aquades



Gambar Garam Dapur



Gambar Cairan Hexadekana

Akrilik percobaan 1 pada air

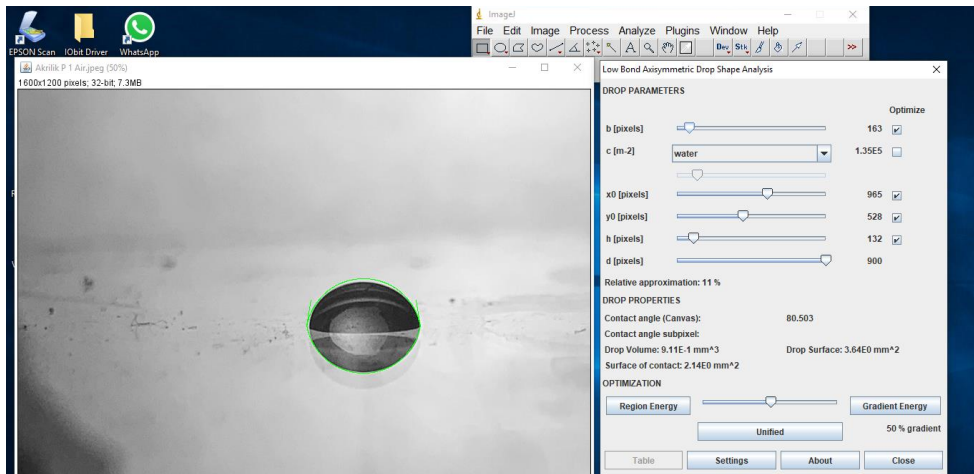

Akrilik Percobaan 2 pada air

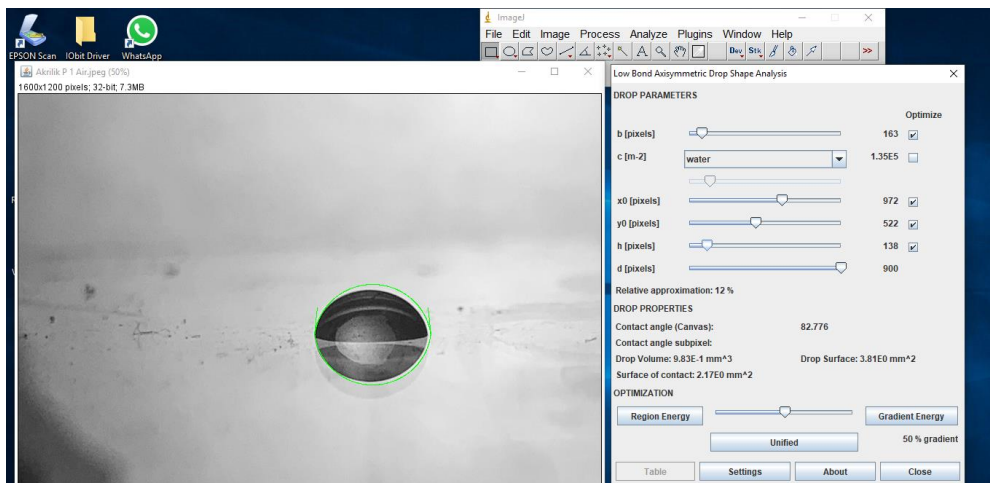

Akrilik Percobaan 3 pada air

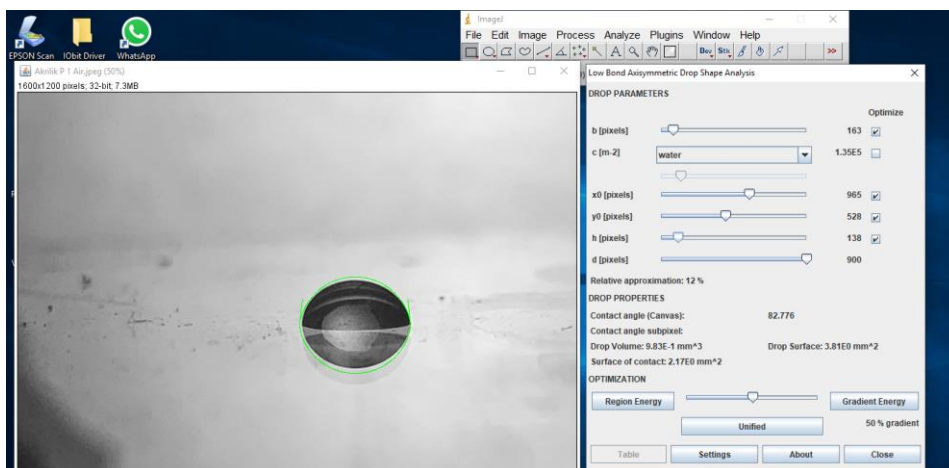

Akrilik Percobaan 1 pada aquades

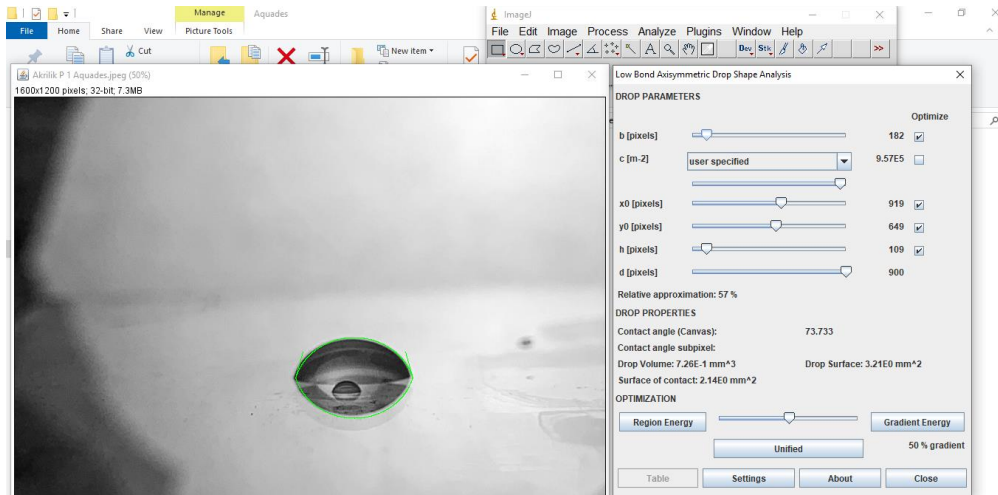

Akrilik Percobaan 2 pada aquades

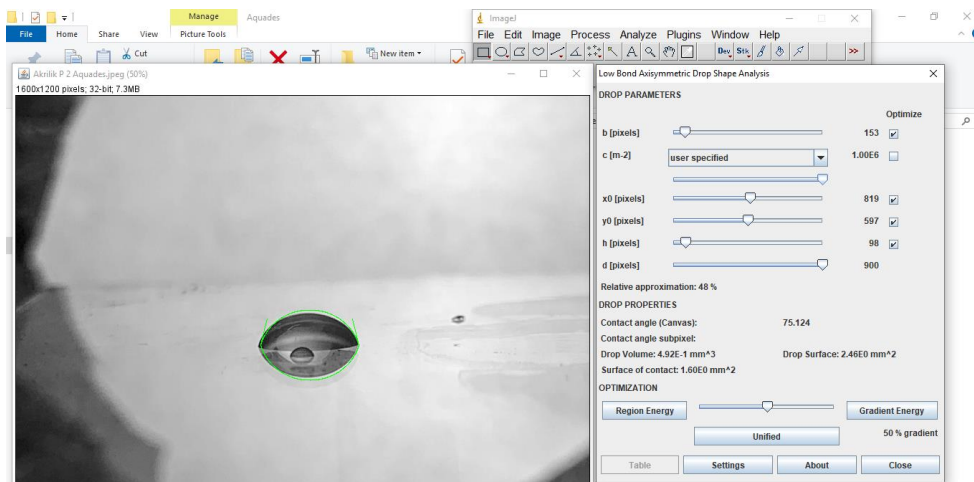

Akrilik Percobaan 3 pada aquades

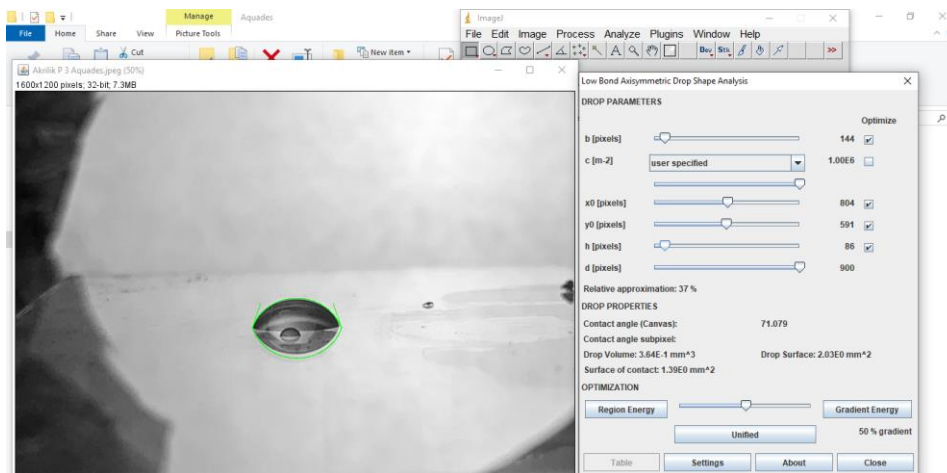

Akrilik Percobaan 1 pada cuka

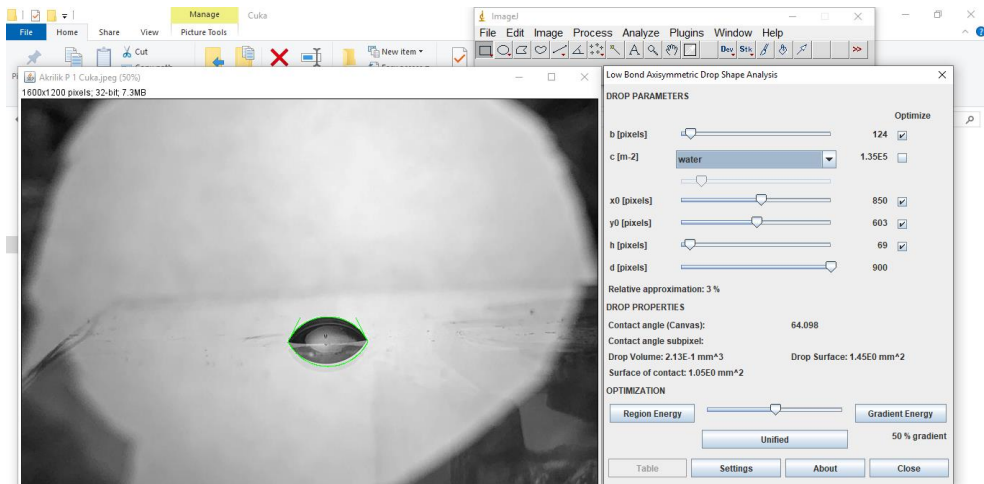

Akrilik Percobaan 2 pada cuka

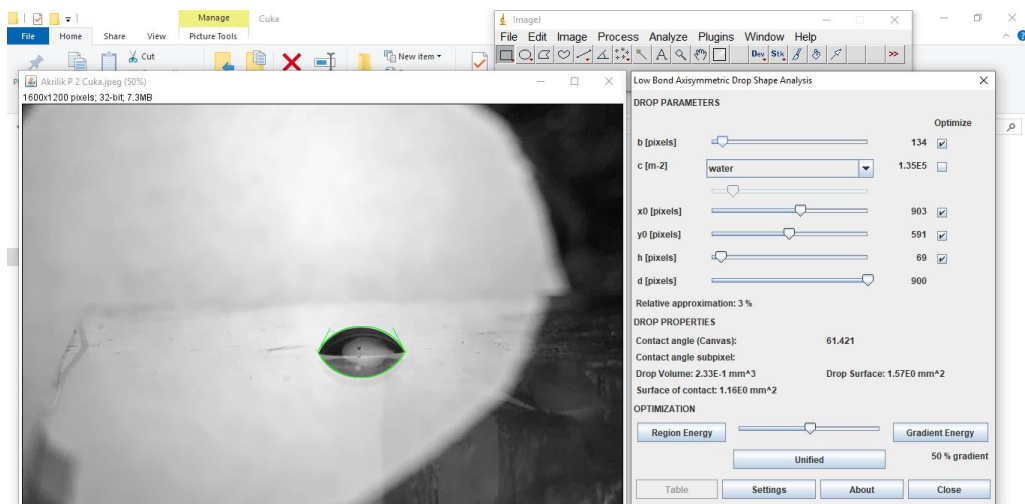

Akrilik Percobaan 3 pada cuka

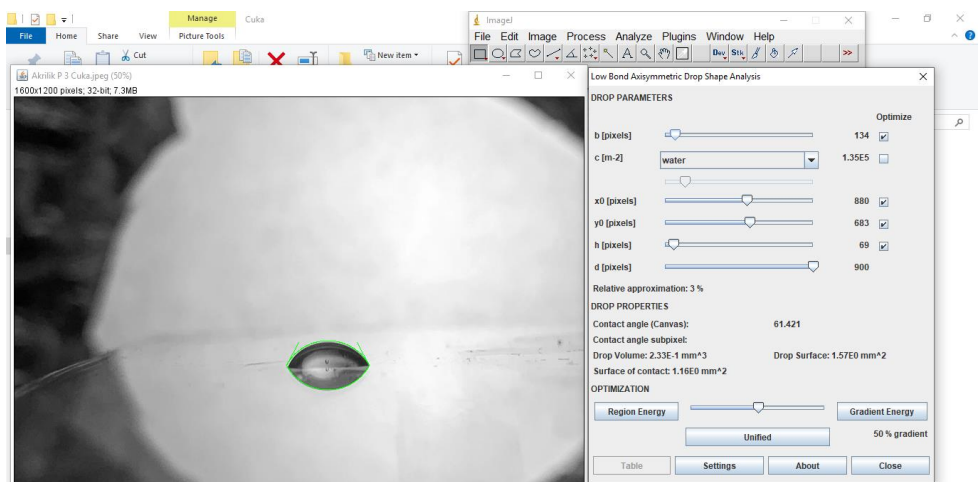

Akrilik Percobaan 1 pada garam

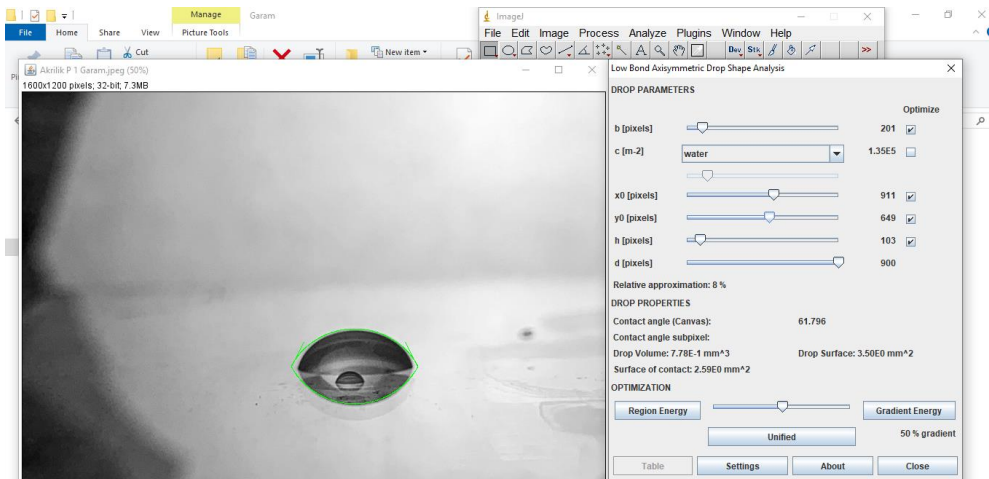

Akrilik Percobaan 2 pada garam

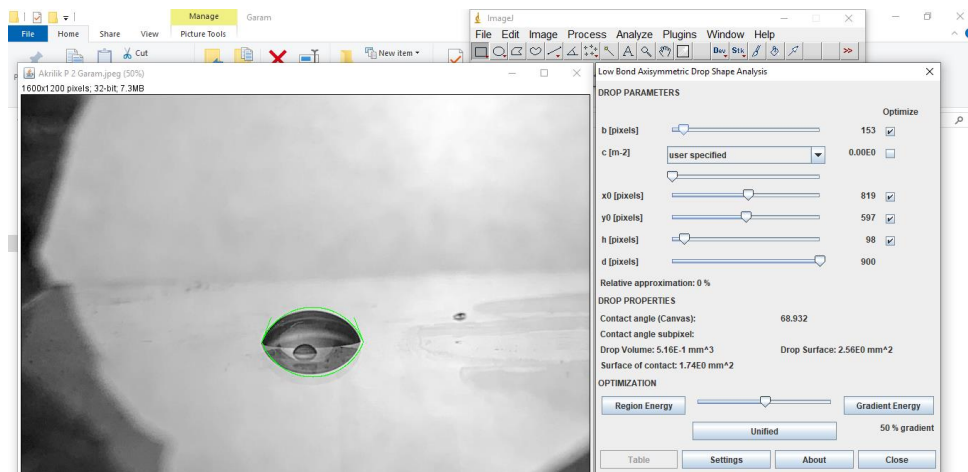

Akrilik Percobaan 3 pada garam

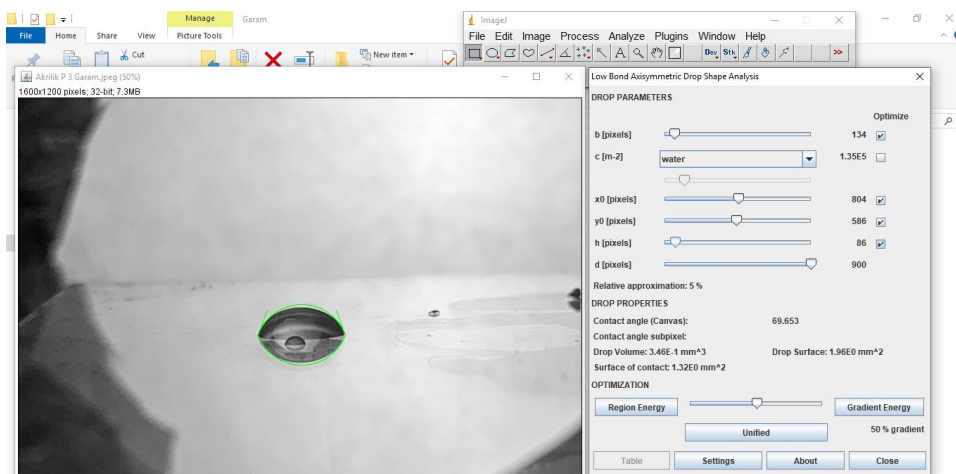

Akrilik Percobaan 1 pada hexadecane

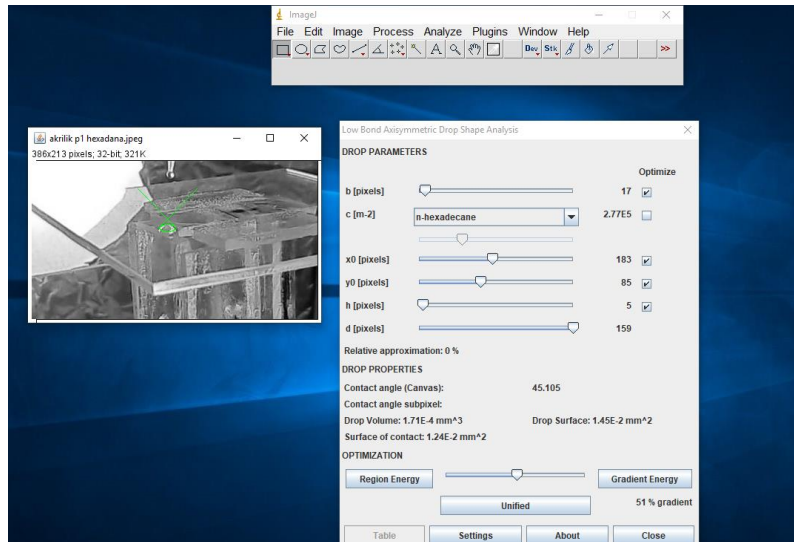

Akrilik Percobaan 2 pada hexadecane

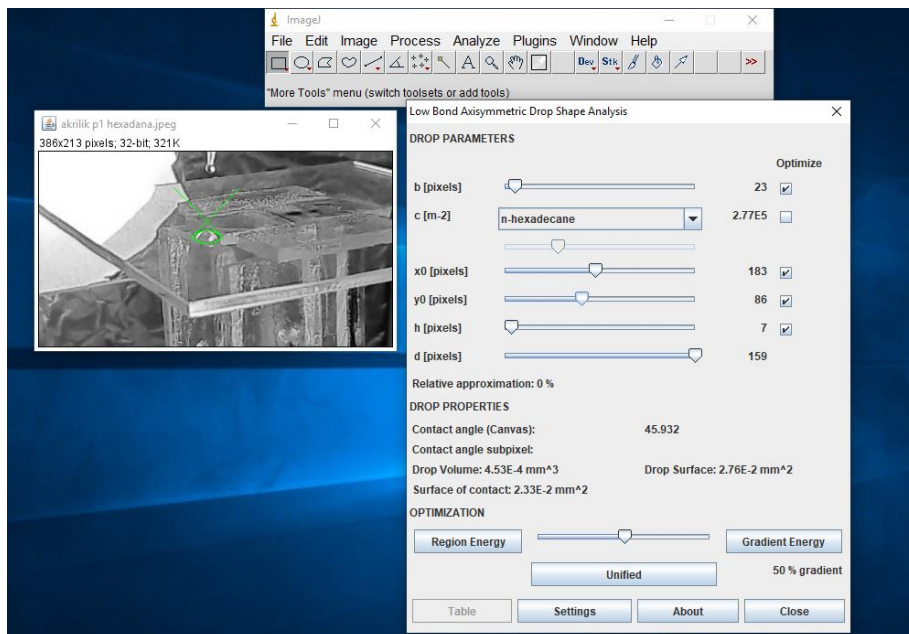

Akrilik Percobaan 3 pada hexadecane

ImageJ 1.47v / Java 1.6.0_20 (64-bit)

File Edit Image Process Analyze Plugins Window Help

ImageJ 1.47v / Java 1.6.0_20 (64-bit)

akrilik p1 hexadana.jpeg
386x213 pixels, 32-bit, 321K

Low Bond Axisymmetric Drop Shape Analysis

DROP PARAMETERS

Parameter	Value	Optimize
b [pixels]	19	<input checked="" type="checkbox"/>
c [m-2]	n-hexadecane 2.77E5	<input type="checkbox"/>
x0 [pixels]	183	<input checked="" type="checkbox"/>
y0 [pixels]	86	<input checked="" type="checkbox"/>
h [pixels]	6	<input checked="" type="checkbox"/>
d [pixels]	159	<input type="checkbox"/>

Relative approximation: 0 %

DROP PROPERTIES

Contact angle (Canvas): 46.835
Contact angle subpixel:
Drop Volume: 2.74E-4 mm³ Drop Surface: 1.95E-2 mm²
Surface of contact: 1.64E-2 mm²

OPTIMIZATION

Region Energy Gradient Energy

Unified 50 % gradient

Table Settings About Close

Aluminium percobaan 1 air

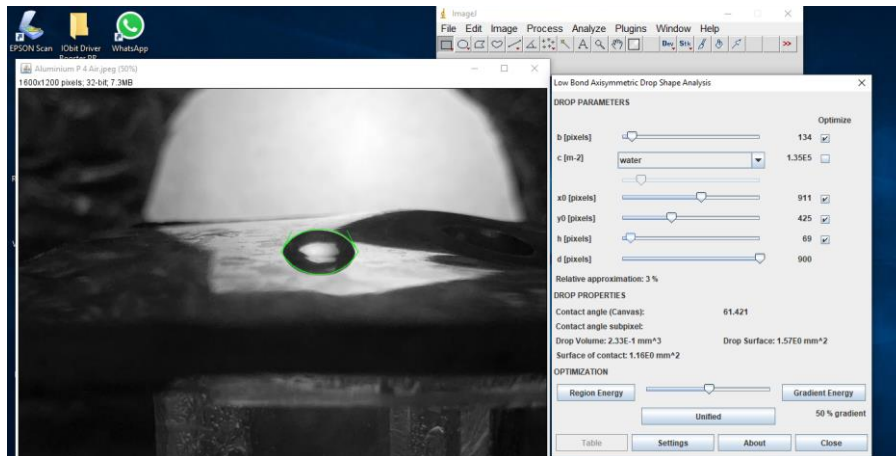

Aluminium percobaan 2 air

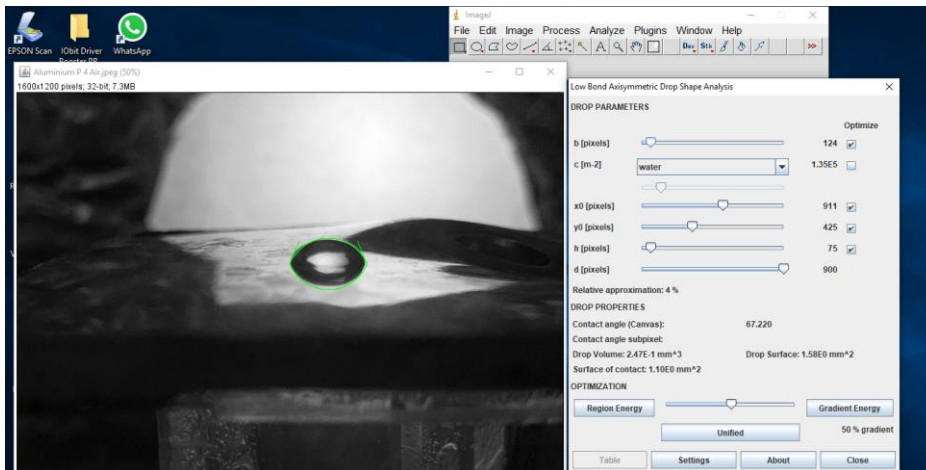

Aluminium percobaan 3 air

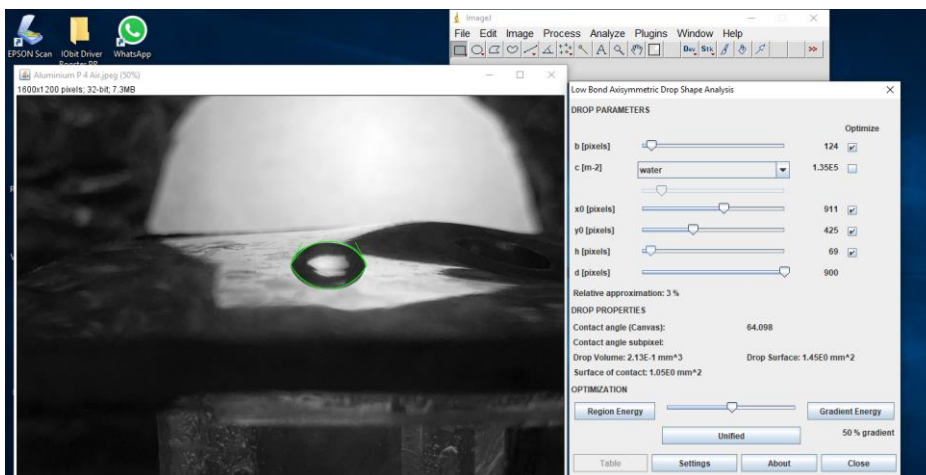

Aluminium percobaan 1 aquades

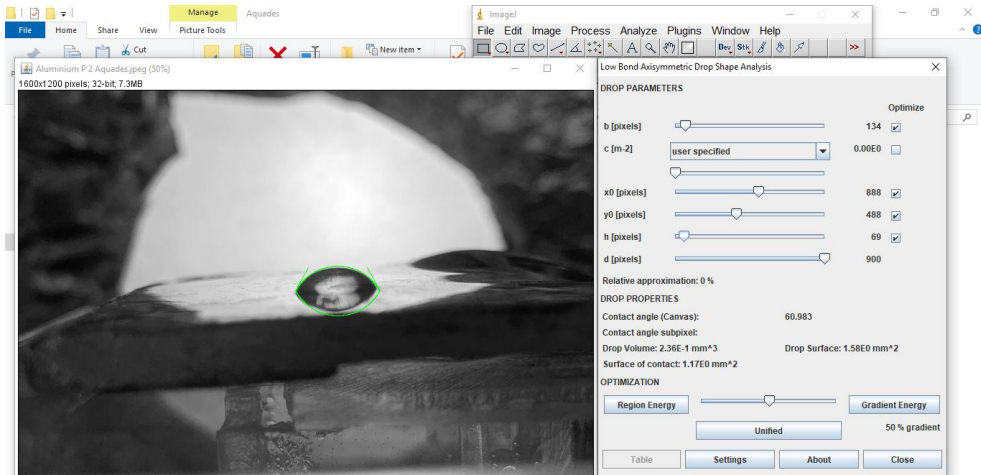

Aluminium percobaan 2 aquades

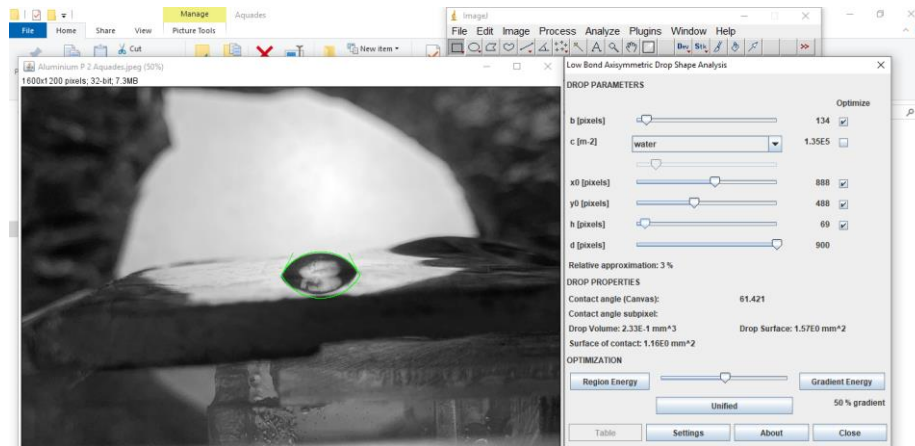

Aluminium percobaan 3 aquades

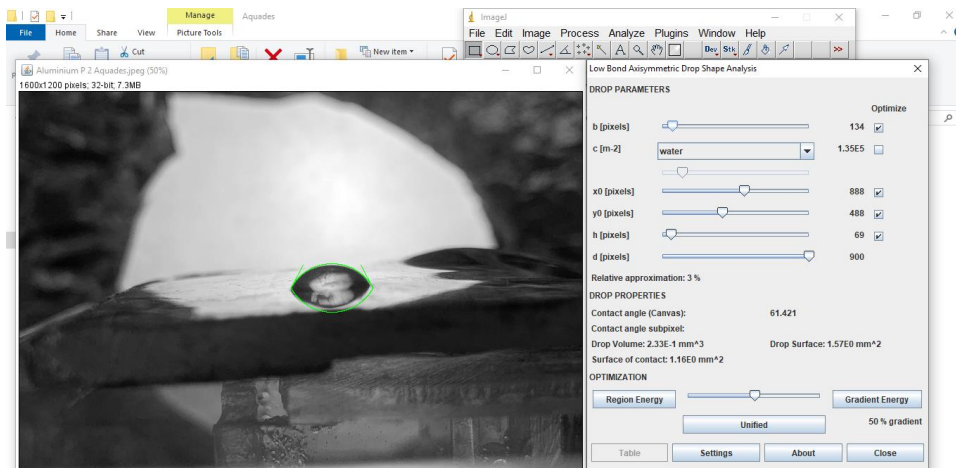

Aluminium percobaan 1 cuka

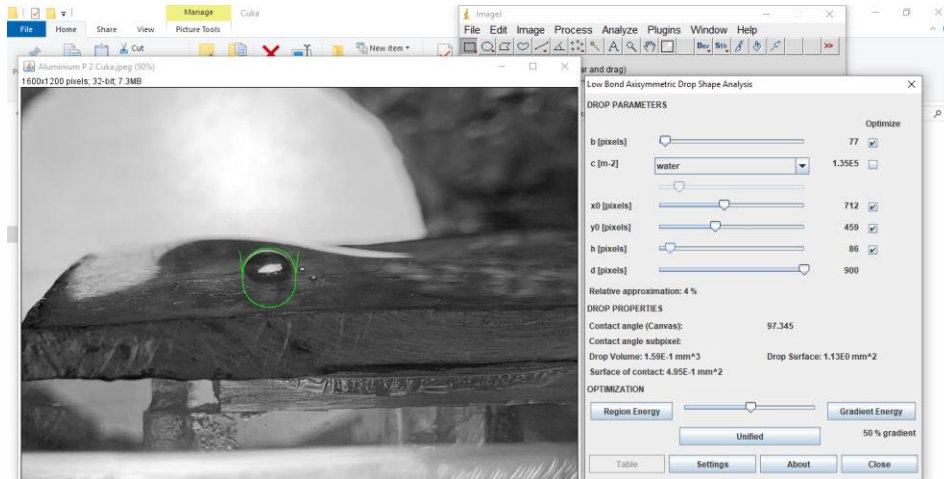

Aluminium percobaan 2 cuka

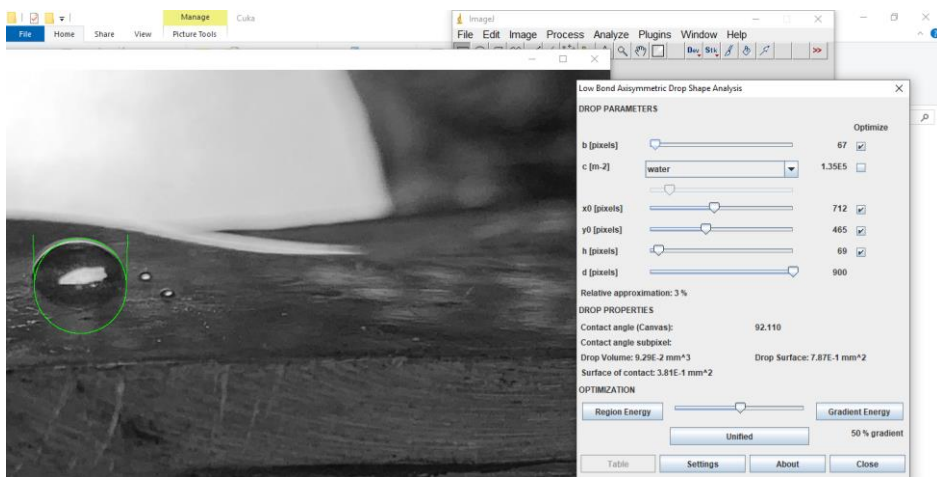

Aluminium percobaan 3 cuka

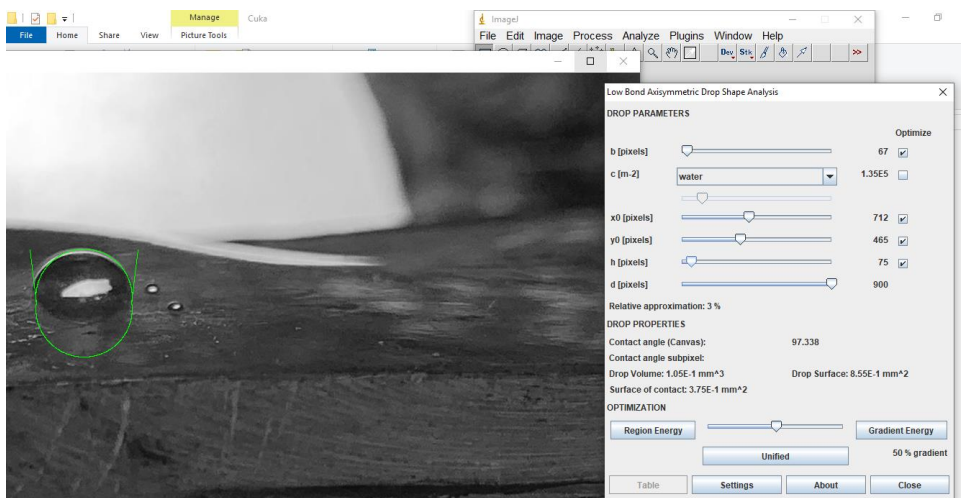

Aluminium percobaan 1 garam

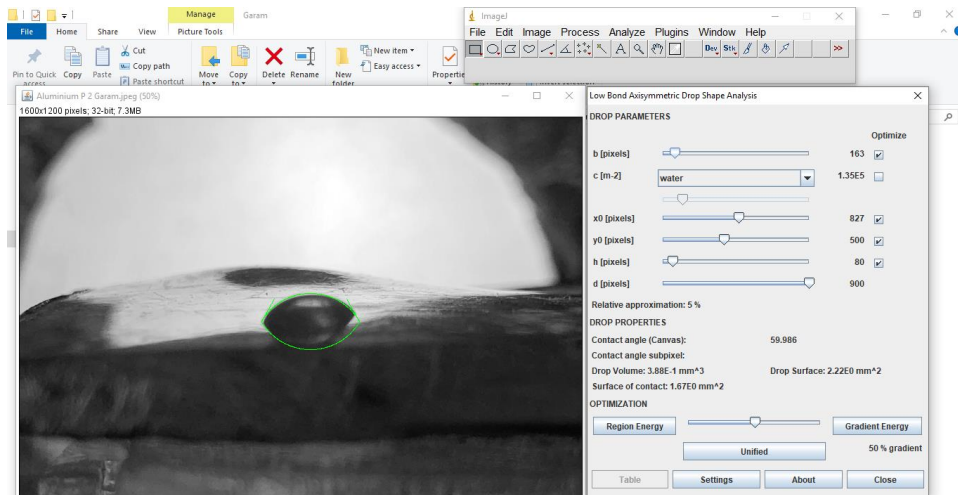

Aluminium percobaan 2 garam

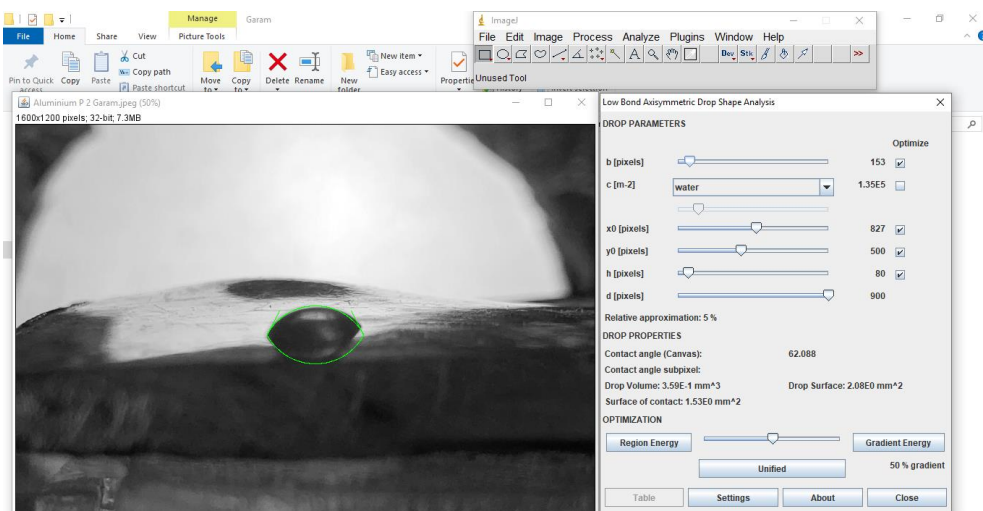

Aluminium percobaan 3 garam

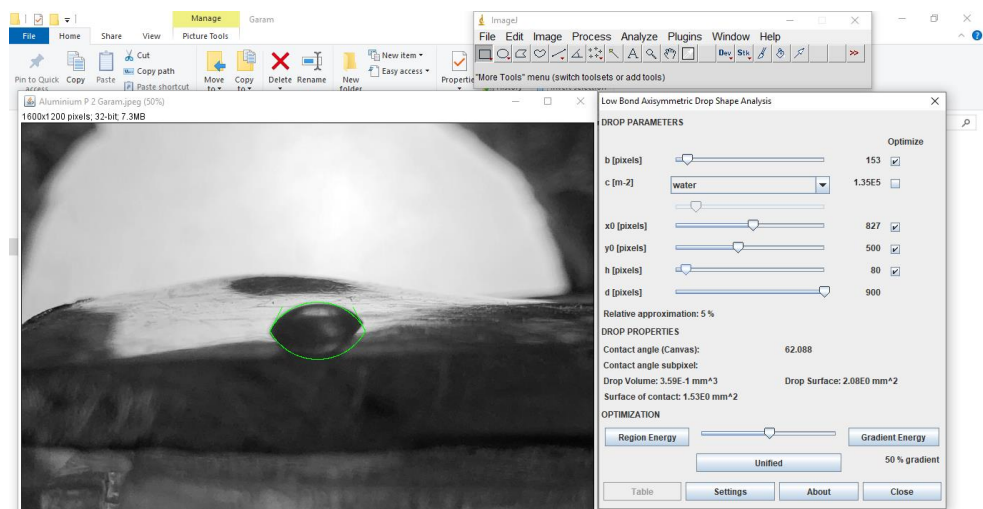

Aluminium percobaan 1 hexadecane

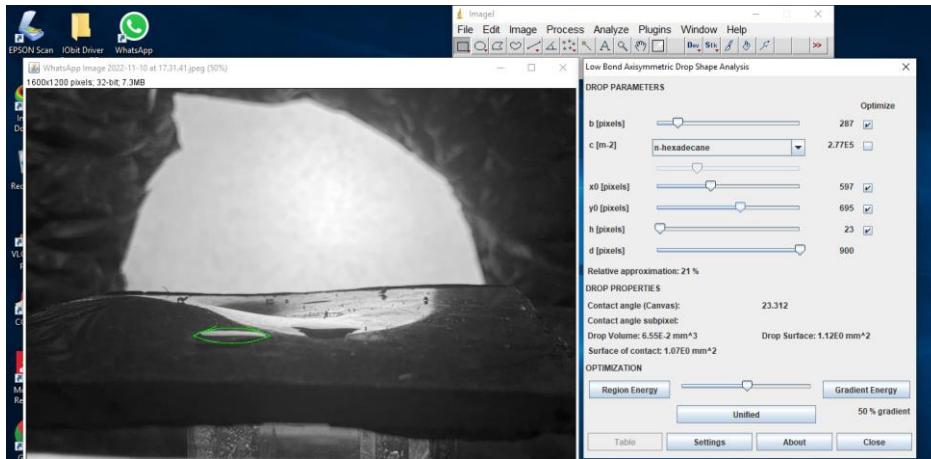

Aluminium percobaan 2 hexadecane

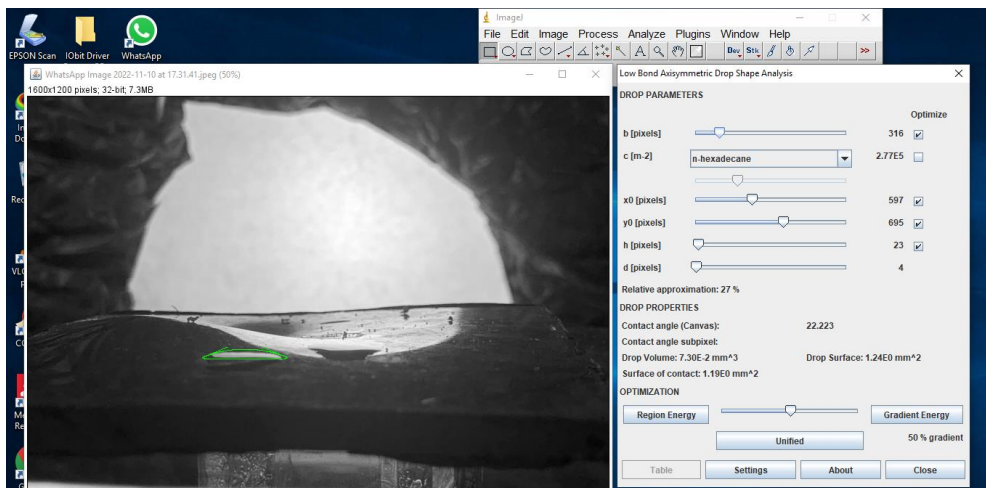

Aluminium percobaan 3 hexadecane

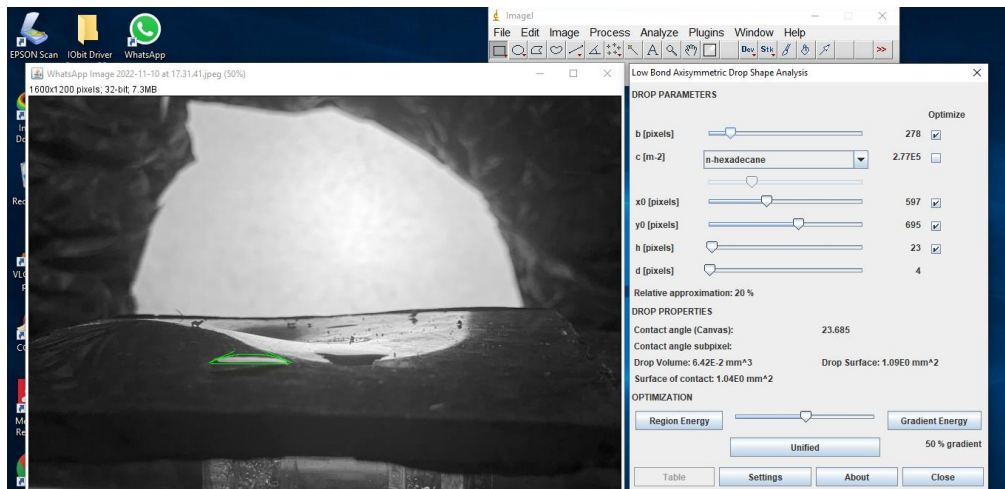

Galvalum percobaan 1 air

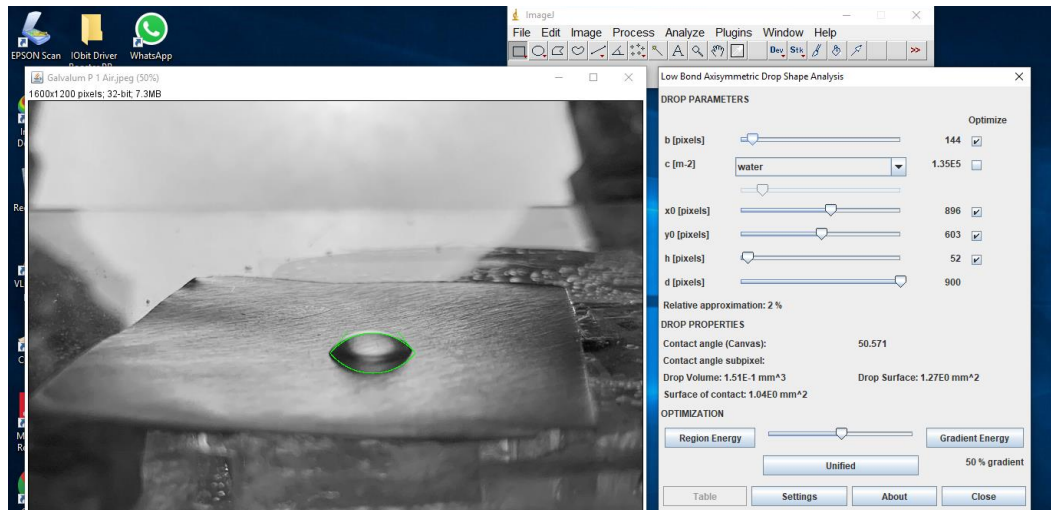

Galvalum percobaan 2 air

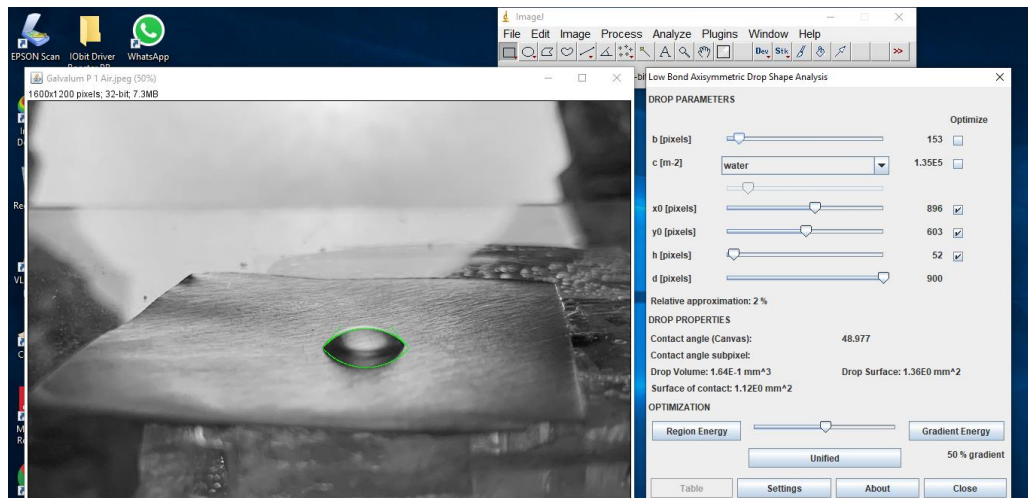

Galvalum percobaan 3 air

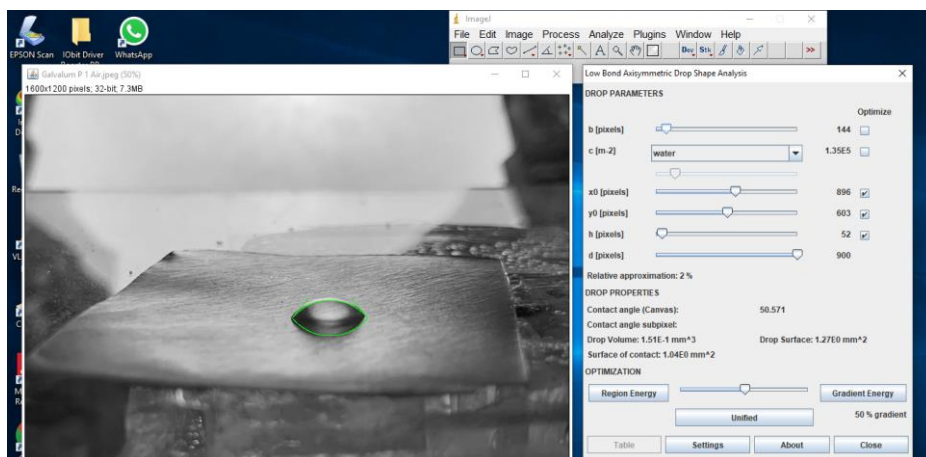

Galvalum percobaan 1 aquades

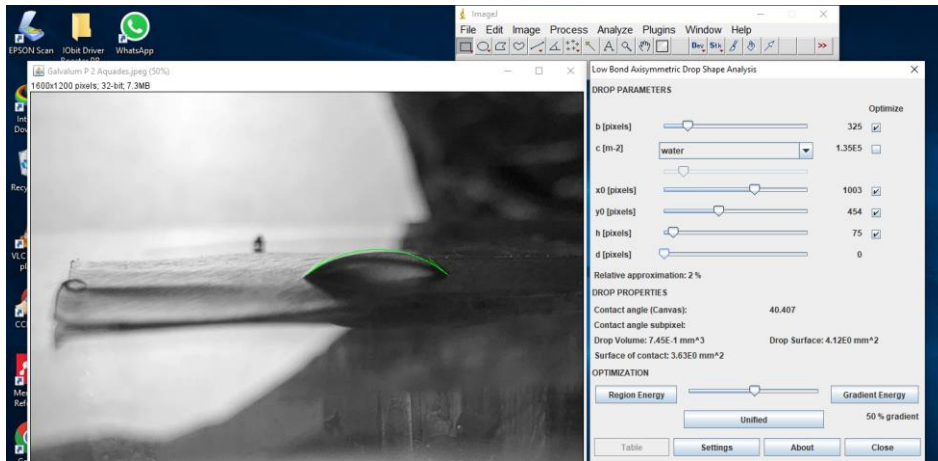

Galvalum percobaan 2 aquades

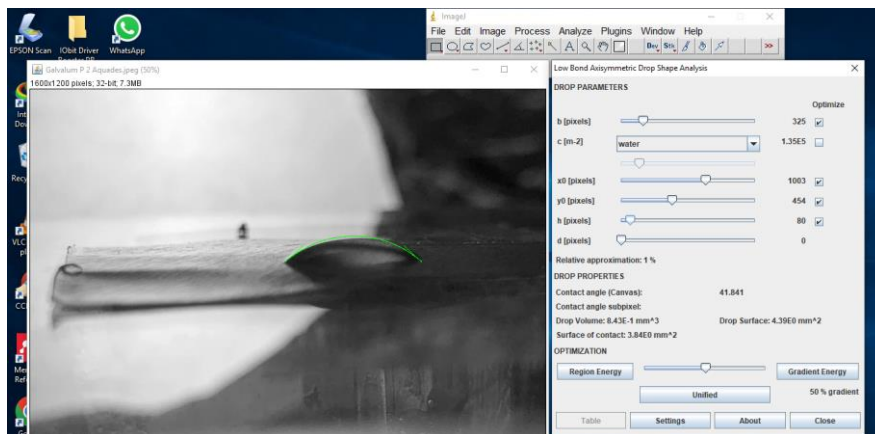

Galvalum percobaan 3 aquades

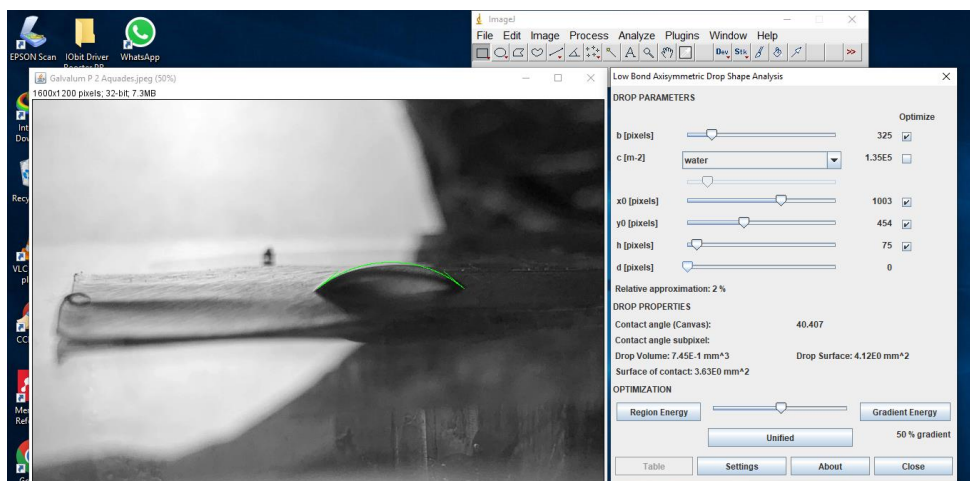

Galvalum percobaan 1 cuka

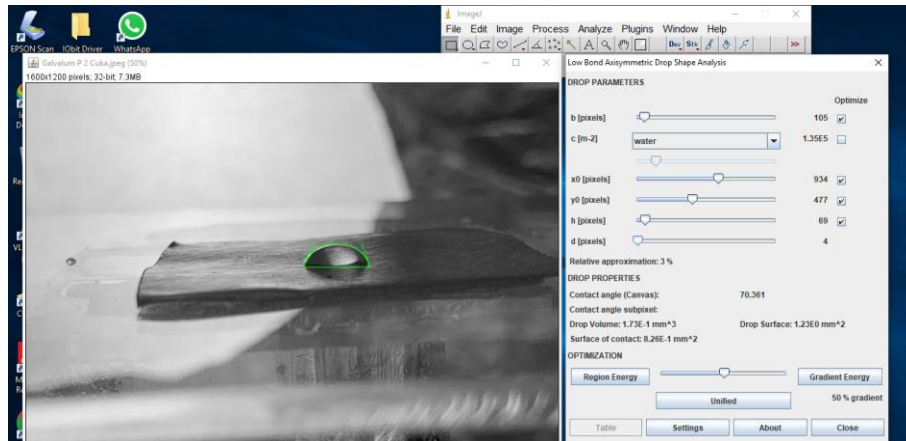

Galvalum percobaan 2 cuka

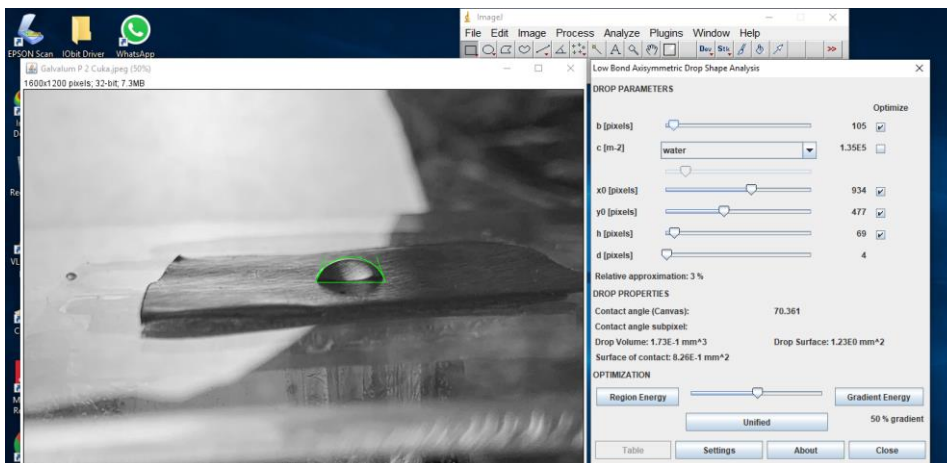

Galvalum percobaan 3 cuka

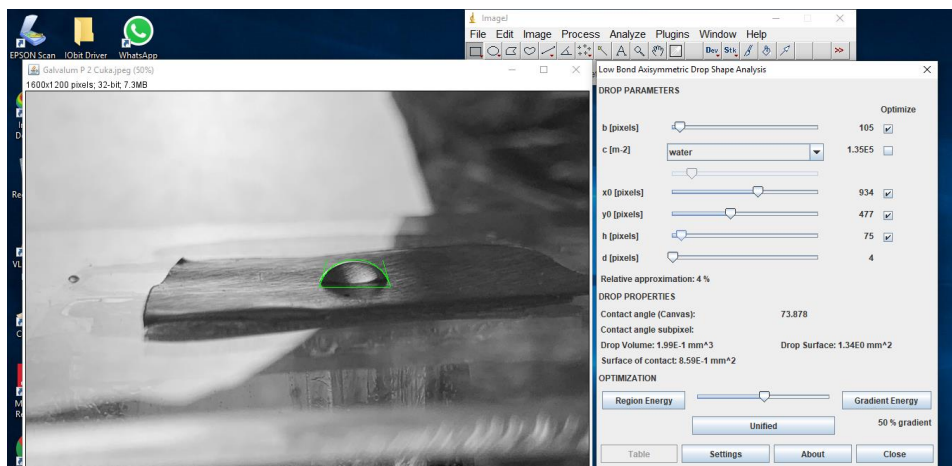

Galvalum percobaan 1 gram

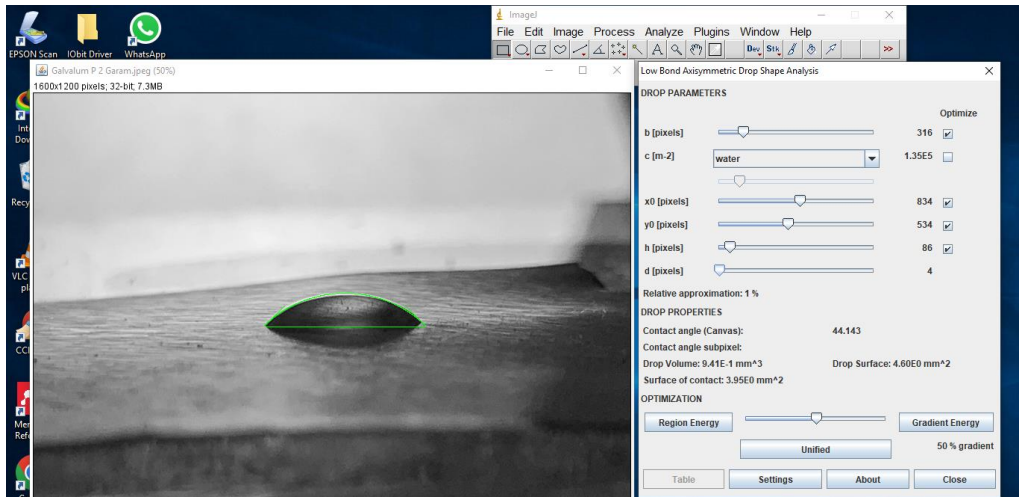

Galvalum percobaan 2 gram

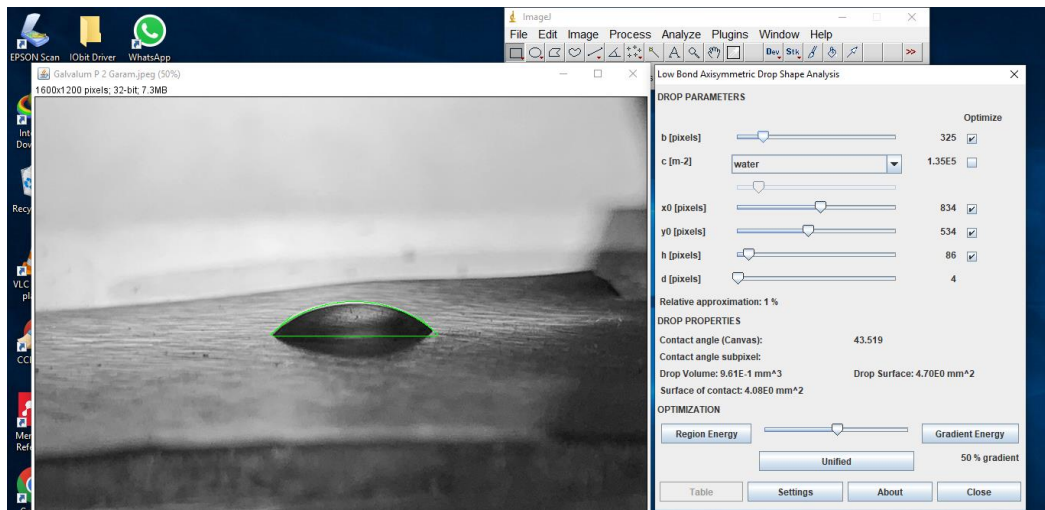

Galvalum percobaan 3 gram

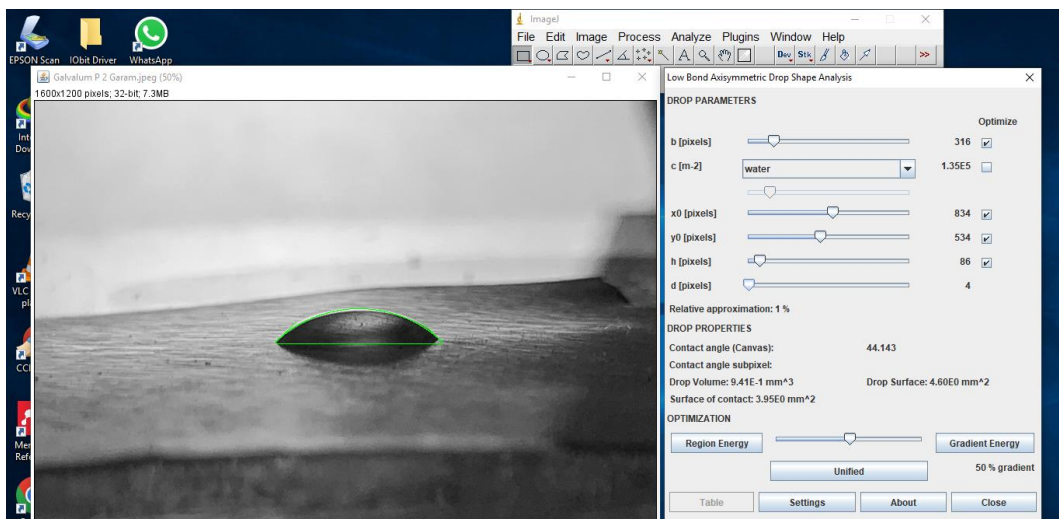

Galvalum percobaan 1 hexadecane

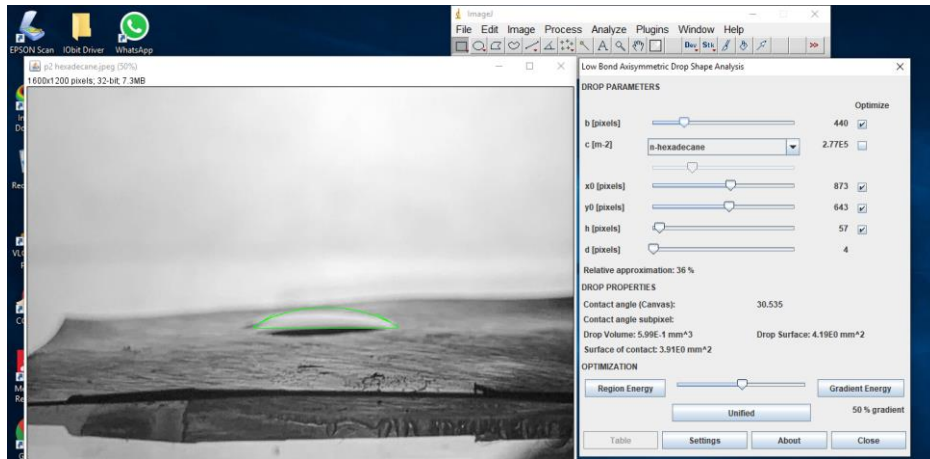

Galvalum percobaan 2 hexadecane

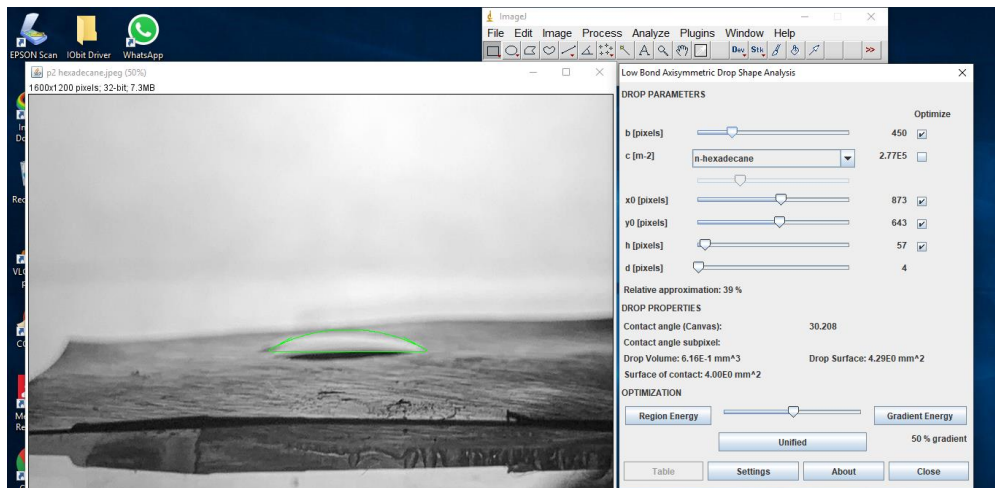

Galvalum percobaan 3 hexadecane

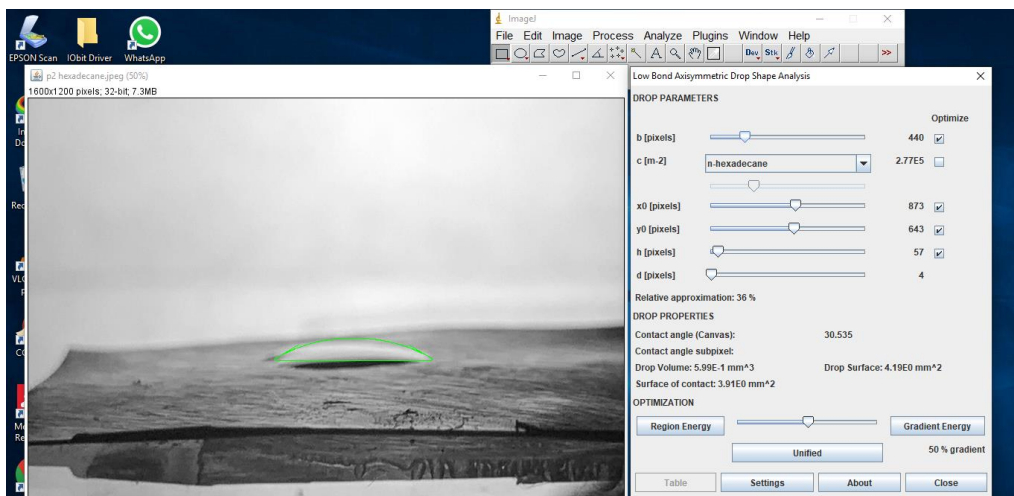

Kaca Percobaan 1 Pada Air

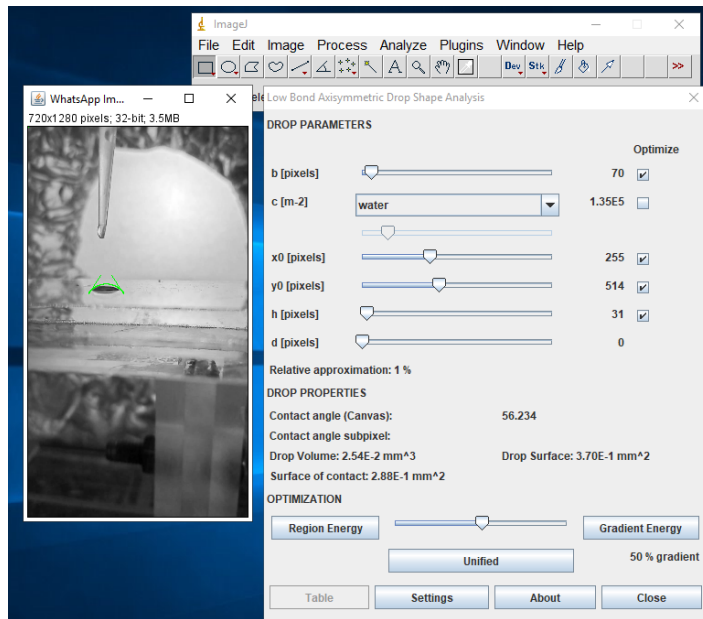

Kaca Percobaan 2 Pada Air

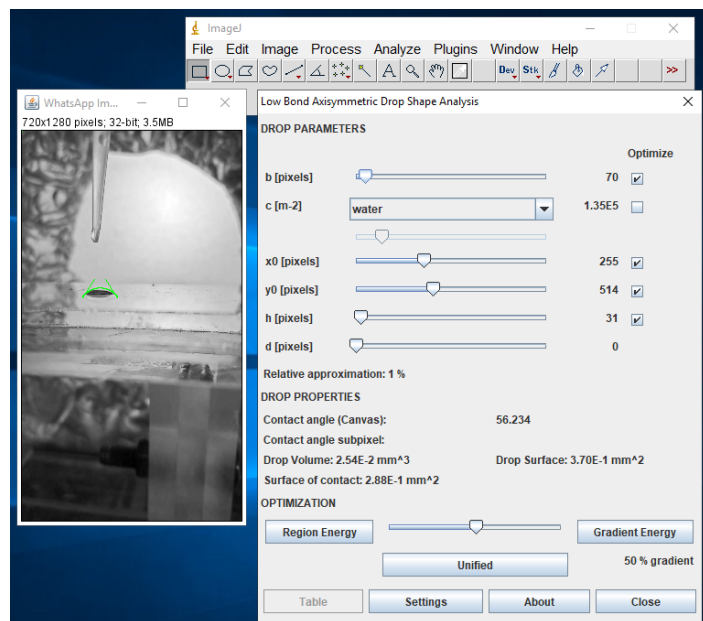

Kaca Percobaan 3 Pada Air

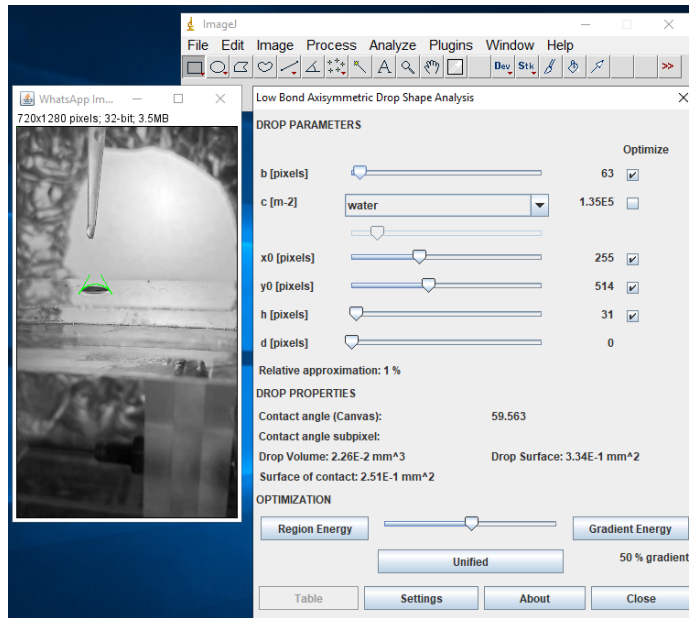

Kaca Percobaan 1 Pada Cuka

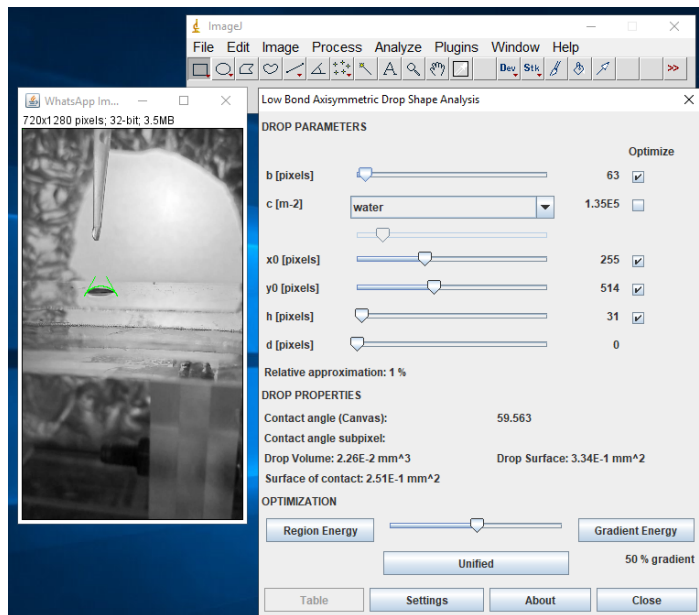

Kaca Percobaan 2 Pada Cuka

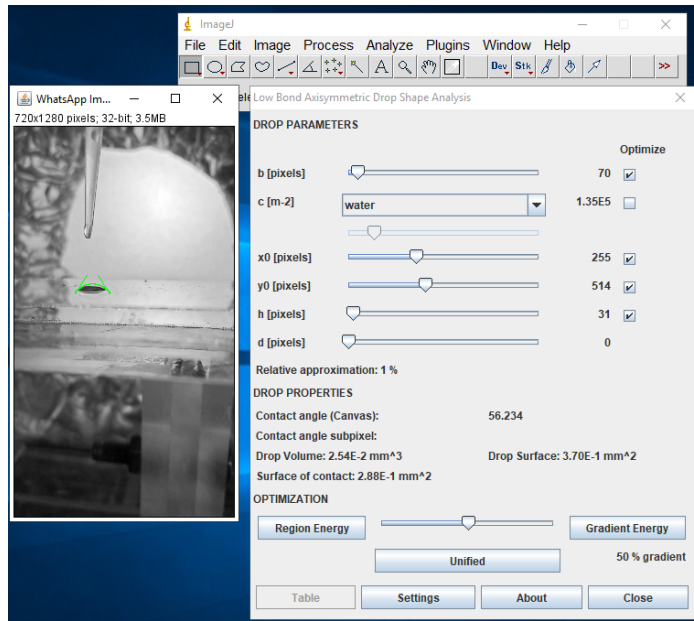

Kaca Percobaan 3 Pada Cuka

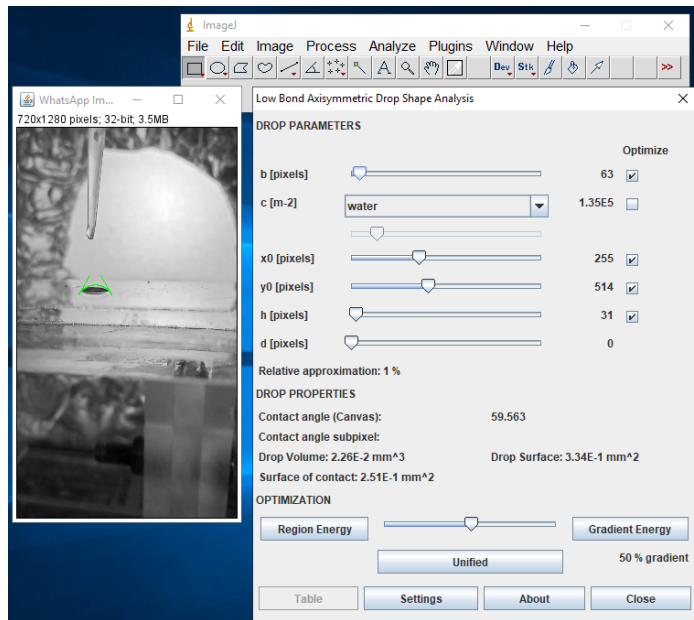

Kaca Percobaan 1 Pada Garam

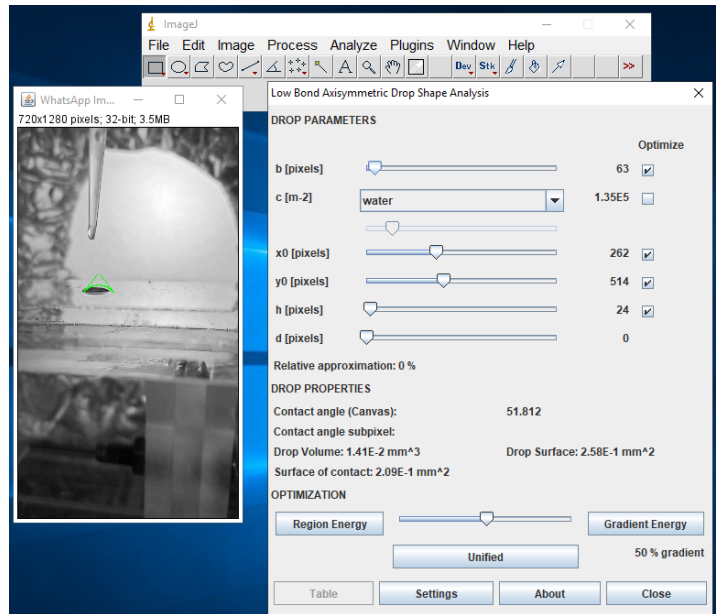

Kaca Percobaan 2 Pada Garam

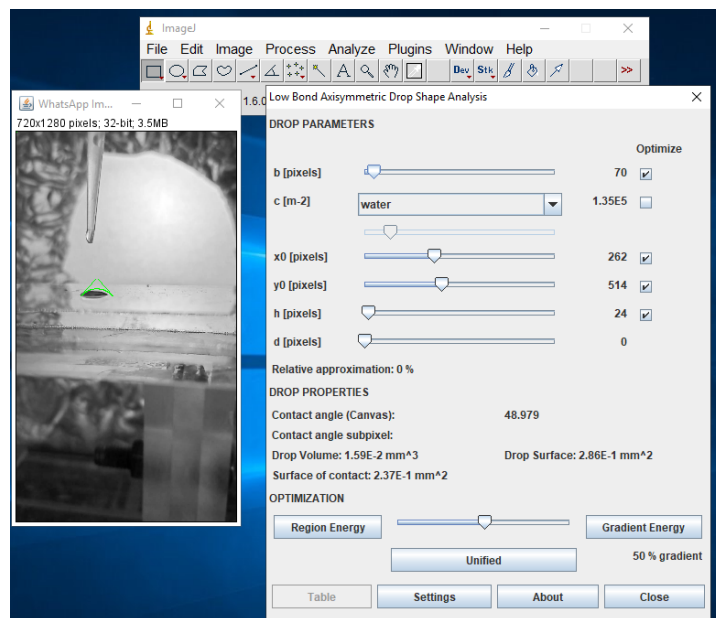

Kaca Percobaan 3 Pada Garam

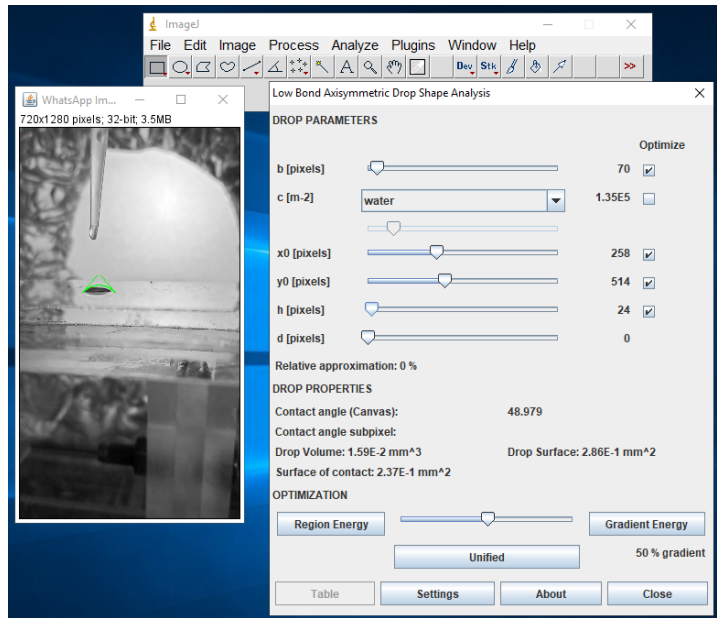

Kaca Percobaan 1 Pada Aquades

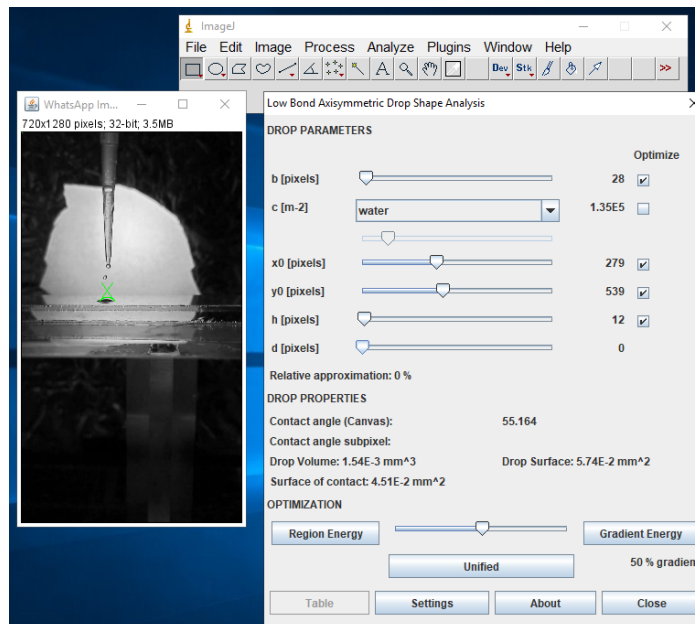

Kaca Percobaan 2 Pada Aquades

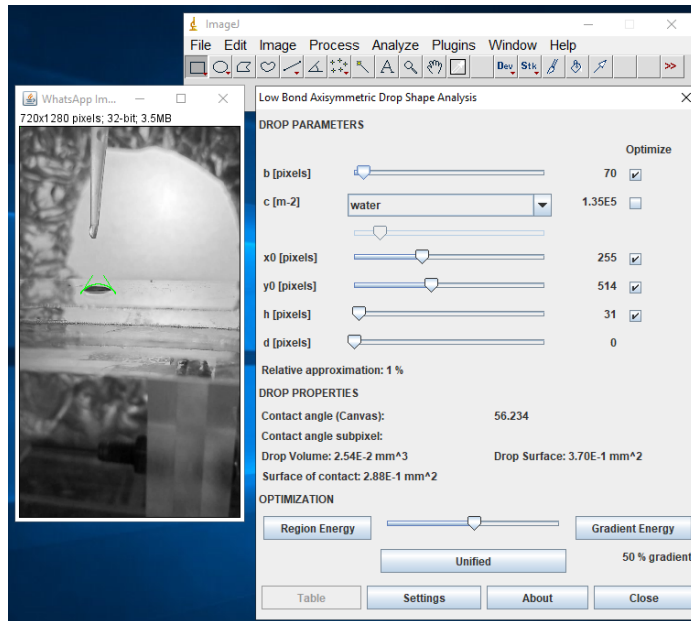

Kaca Percobaan 3 Pada Aquades

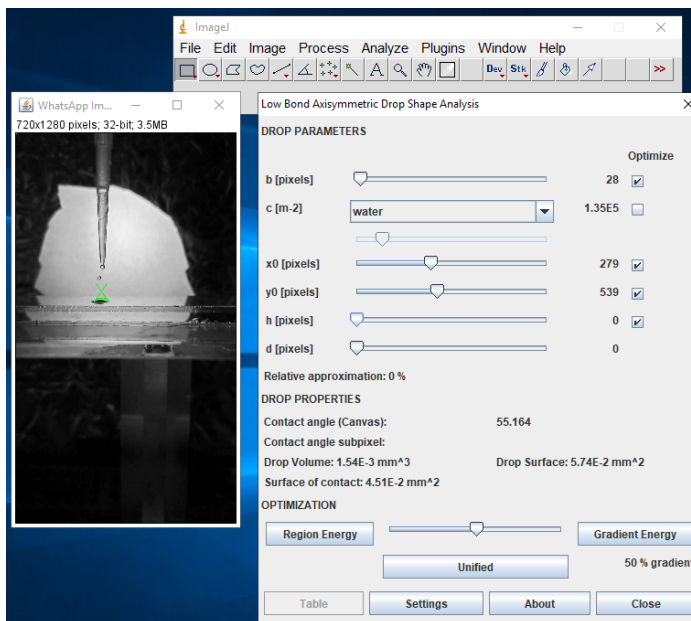

Kaca Percobaan 1 Pada Hexadekana

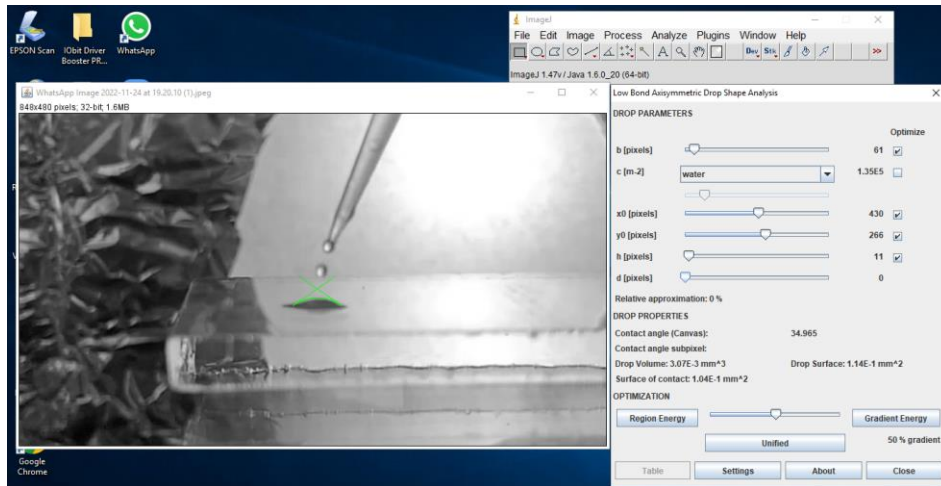

Kaca Percobaan 2 Pada Hexadkana

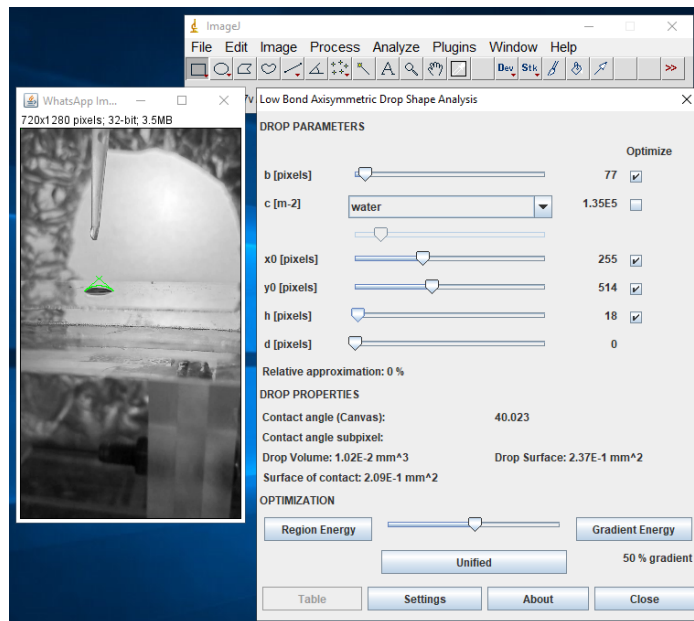

Kaca Percobaan 3 Pada Hexadkana

ImageJ

File Edit Image Process Analyze Plugins Window Help

WhatsApp im... 720x1280 pixels, 32-bit, 3.5MB

Low Bond Axisymmetric Drop Shape Analysis

DROP PARAMETERS

b [pixels]	<input type="text" value="98"/>	Optimize <input checked="" type="checkbox"/>
c [m-2]	water	1.35E5 <input type="checkbox"/>
x0 [pixels]	<input type="text" value="255"/>	255 <input checked="" type="checkbox"/>
y0 [pixels]	<input type="text" value="514"/>	514 <input checked="" type="checkbox"/>
h [pixels]	<input type="text" value="18"/>	18 <input checked="" type="checkbox"/>
d [pixels]	<input type="text" value="0"/>	0 <input type="checkbox"/>

Relative approximation: 0 %

DROP PROPERTIES

Contact angle (Canvas): 35.326

Contact angle subpixel:

Drop Volume: 1.33E-2 mm³ Drop Surface: 3.02E-1 mm²

Surface of contact: 2.73E-1 mm²

OPTIMIZATION

Region Energy Gradient Energy

Unified 50 % gradient

Table Settings About Close

Mild steel percobaan 1 hexadecane

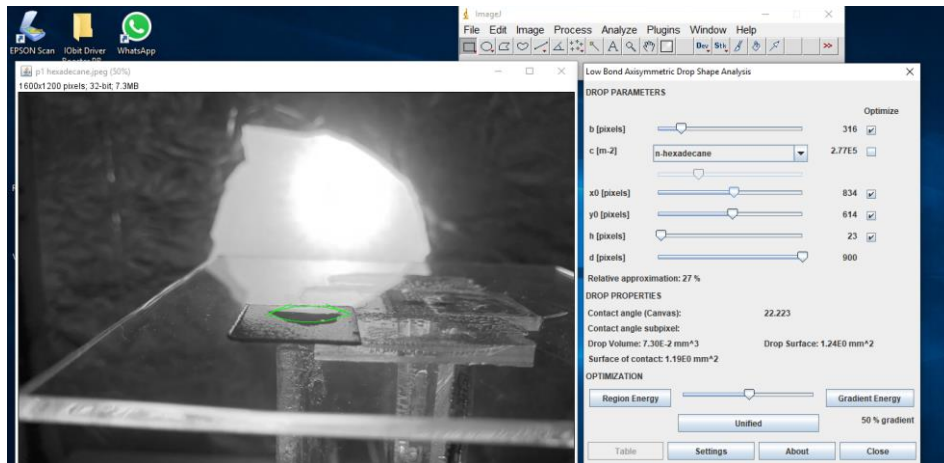

Mild steel percobaan 2 hexadecane

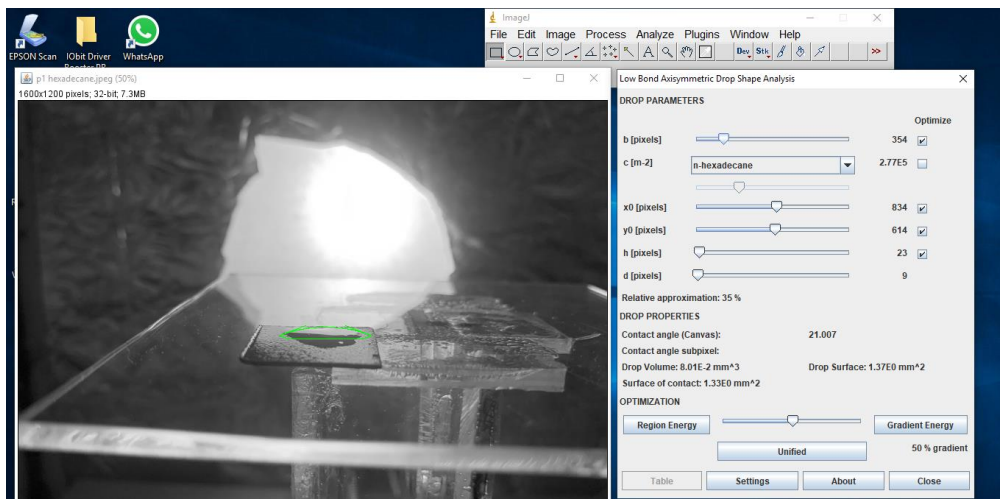

Mild steel percobaan 3 hexadecane

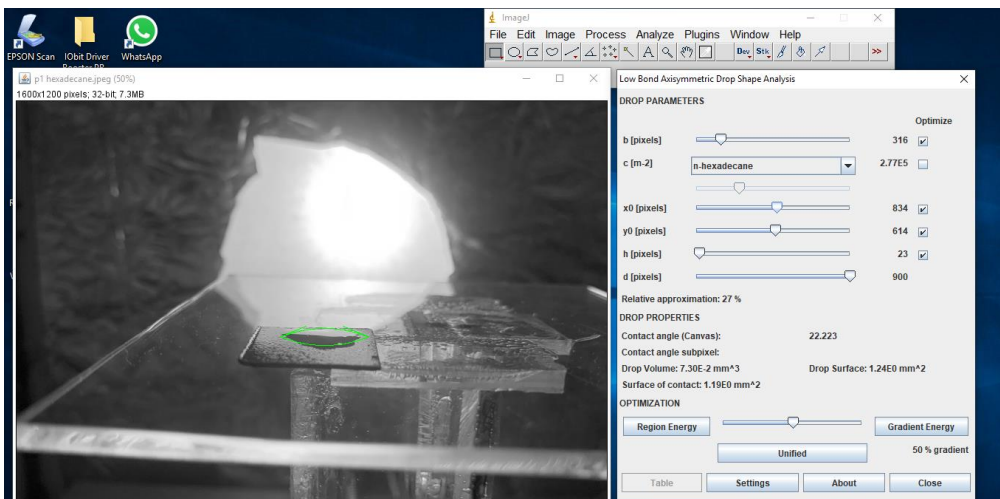

Mild steel percobaan 1 air

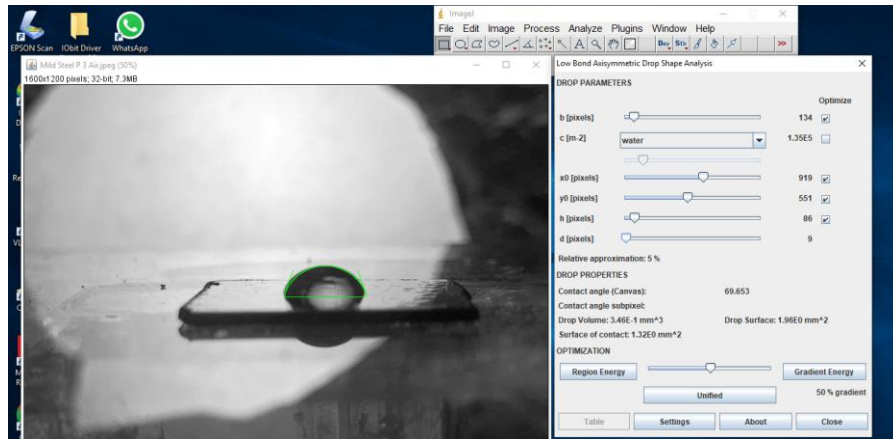

Mild steel percobaan 2 air

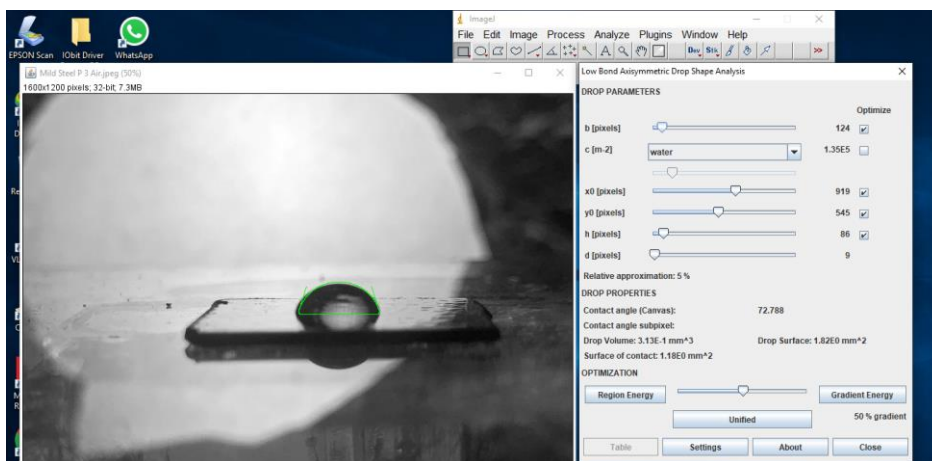

Mild steel percobaan 3 air

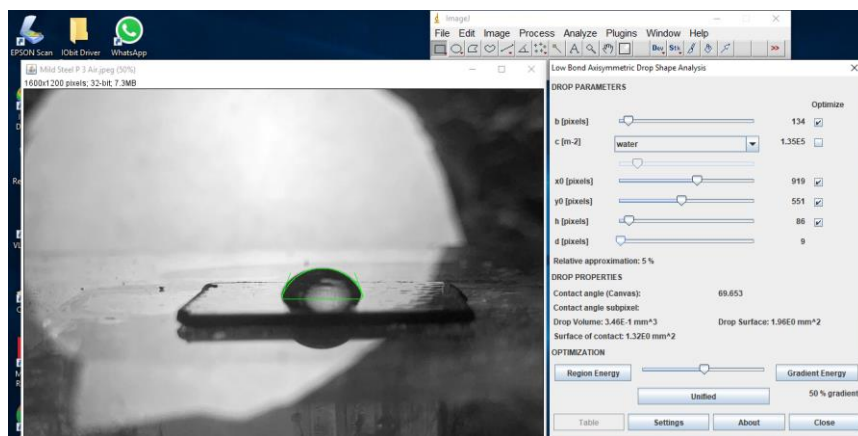

Mild steel percobaan 1 aquades

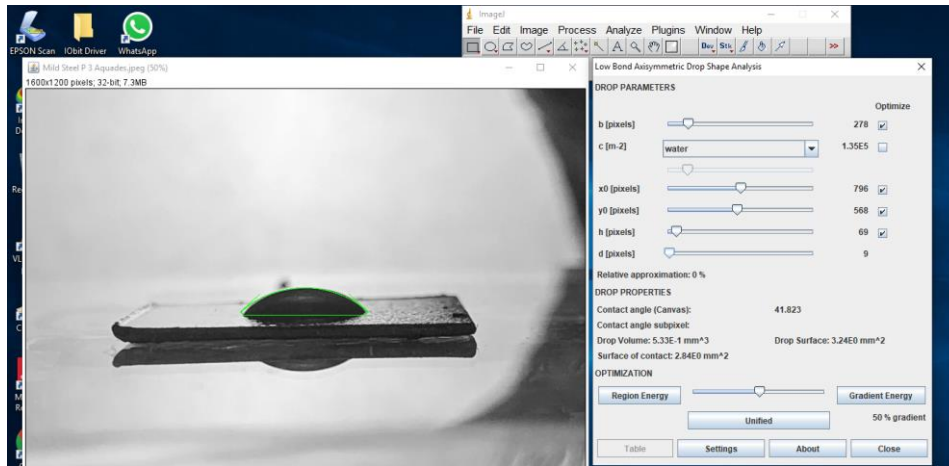

Mild steel percobaan 2 aquades

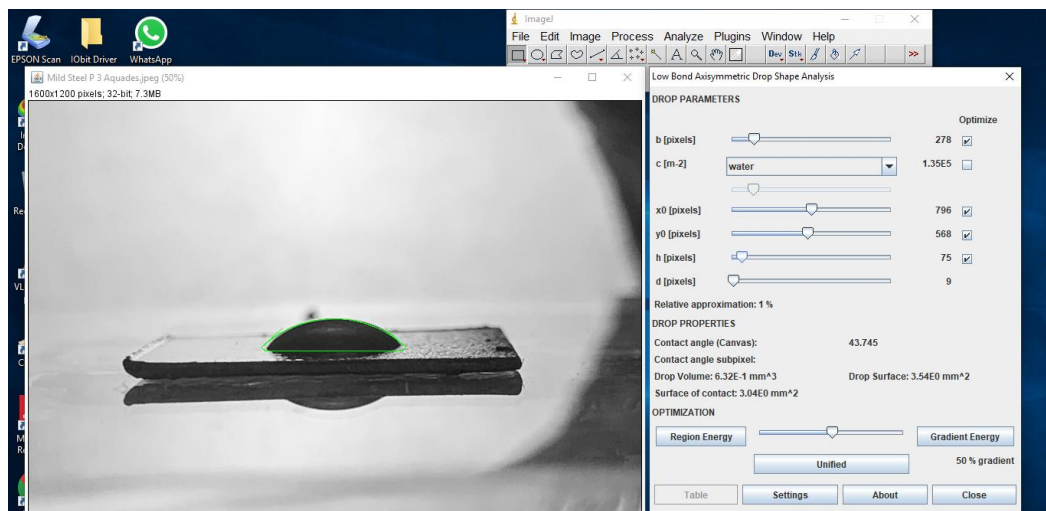

Mild steel percobaan 3 aquades

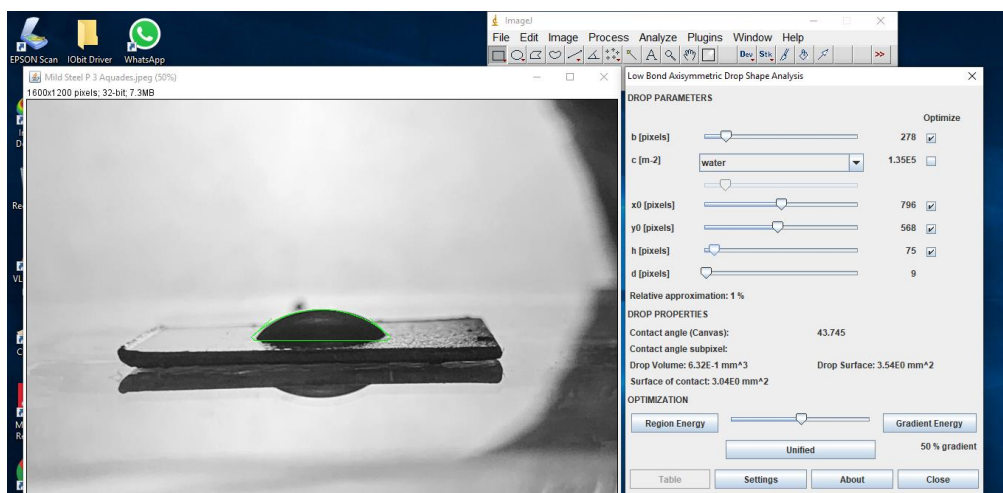

Mild steel percobaan 1 cuka

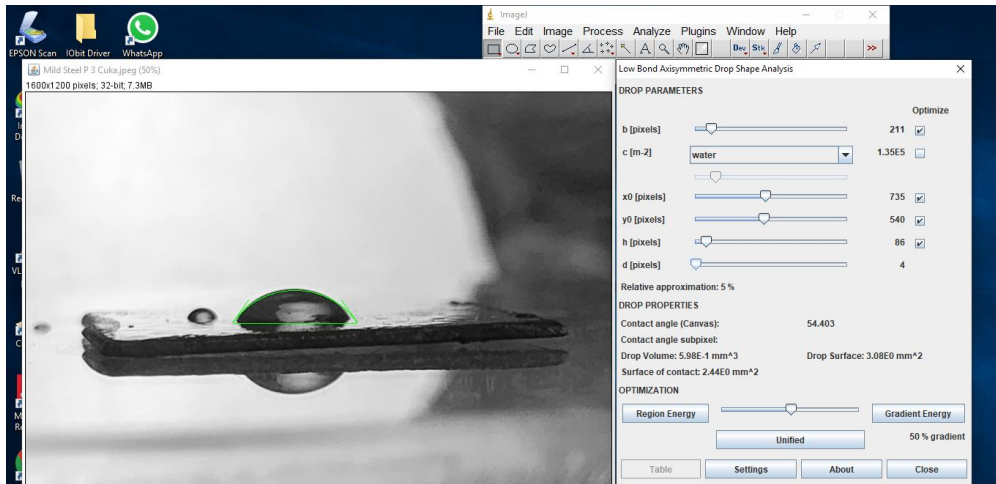

Mild steel percobaan 2 cuka

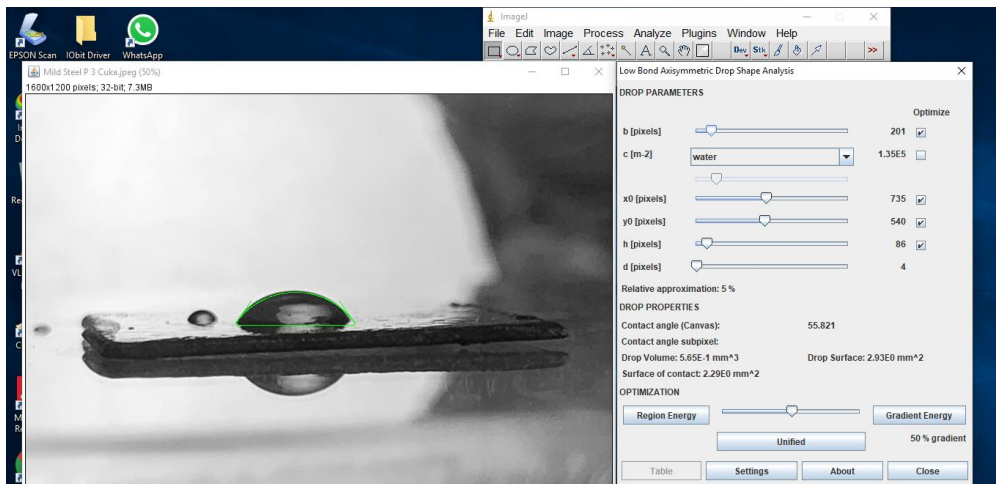

Mild steel percobaan 3 cuka

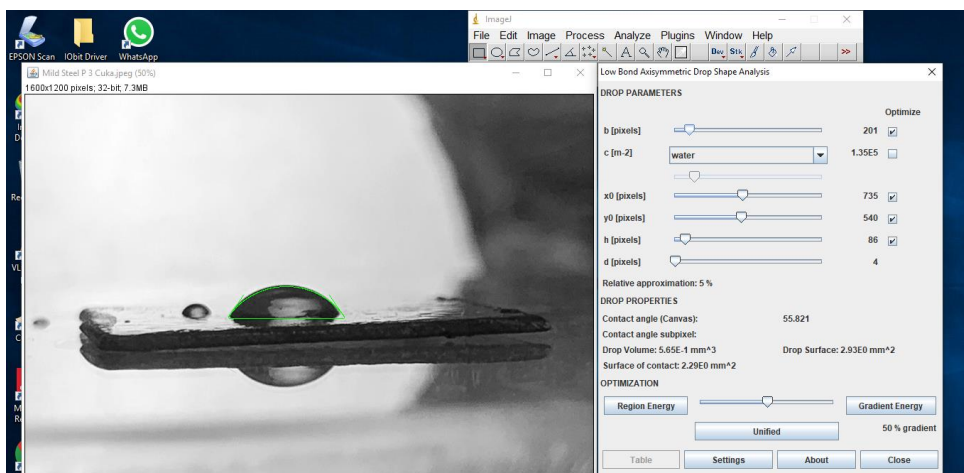

Mild steel percobaan 1 gram

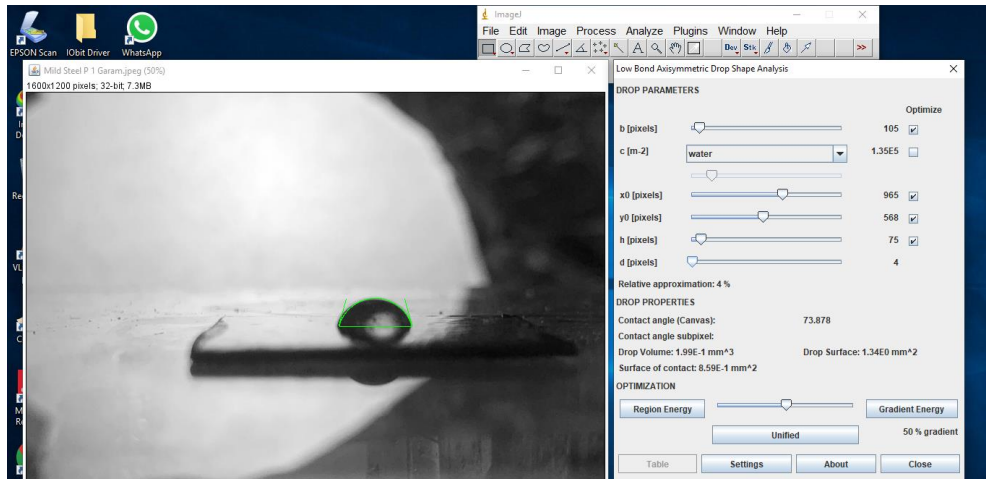

Mild steel percobaan 2 garam

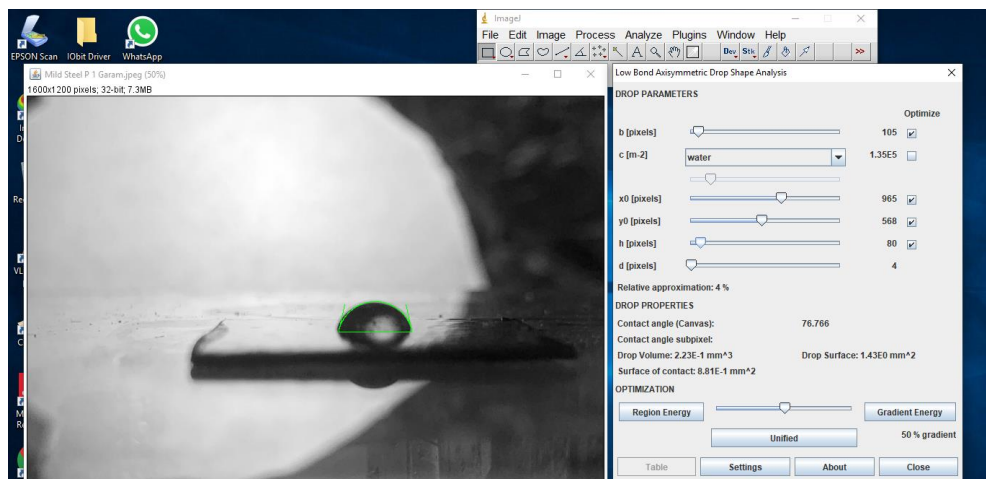

Mild steel percobaan 3 garam

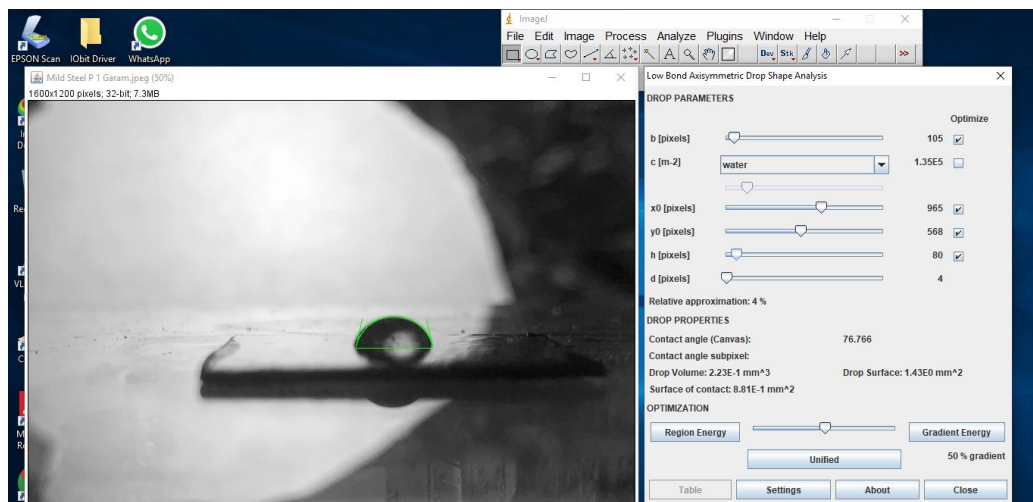

Styrofoam percobaan 1 hexadecane

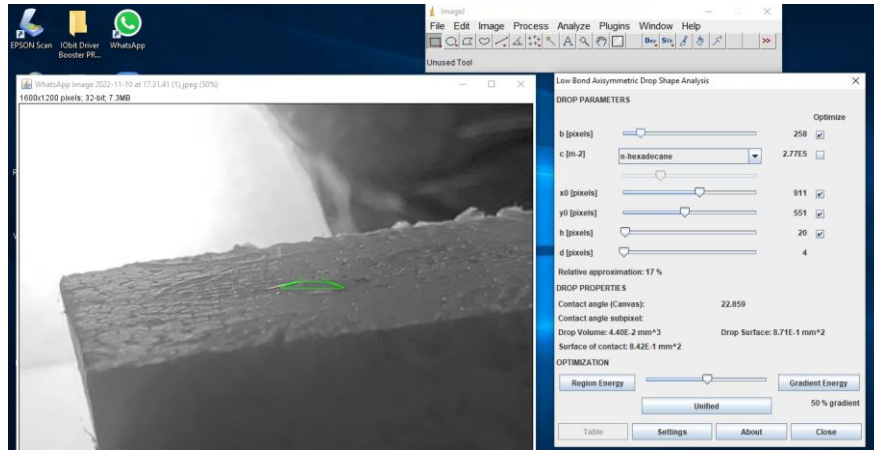

Styrofoam percobaan 2 hexadecane

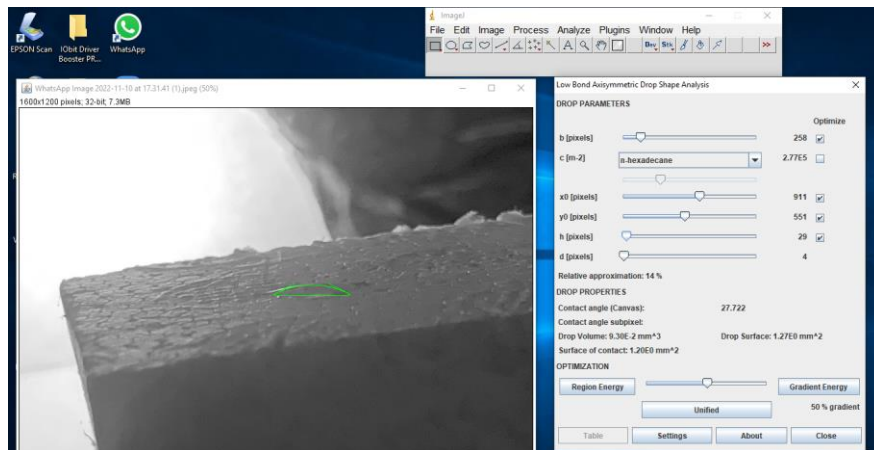

Styrofoam percobaan 3 hexadecane

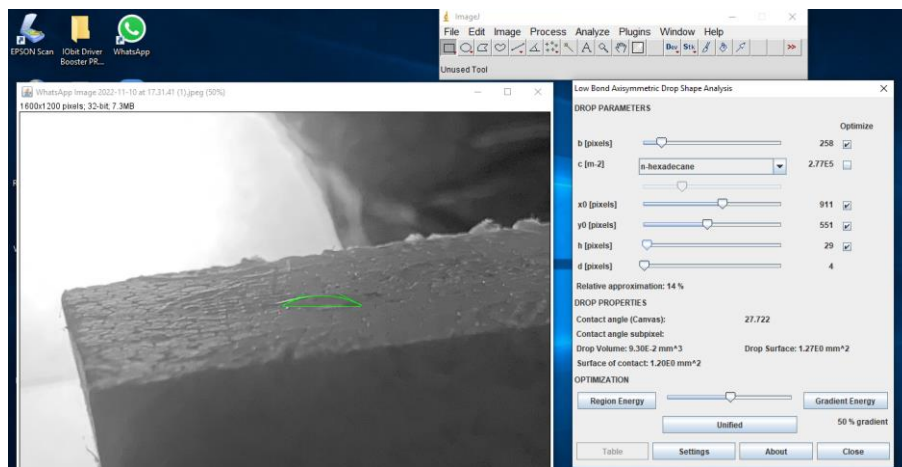

Styrofoam percobaan 1 air

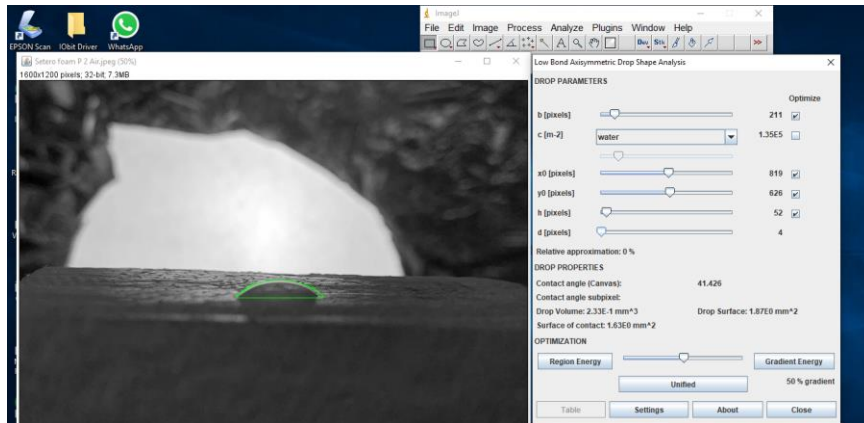

Styrofoam percobaan 2 air

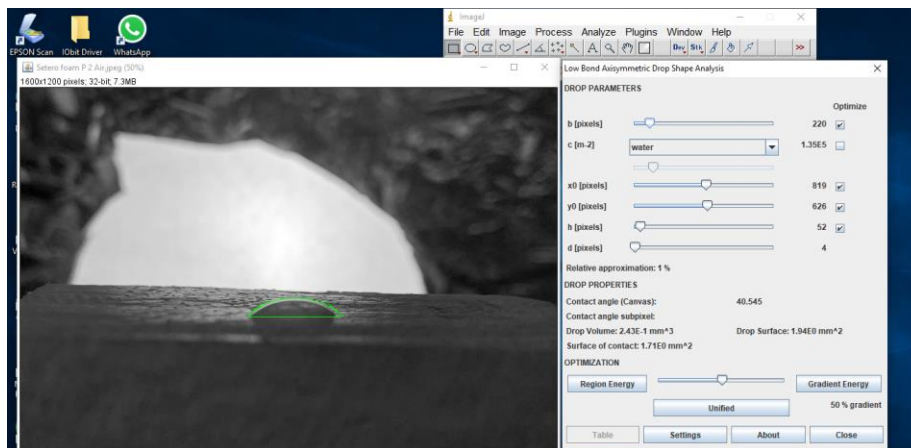

Styrofoam percobaan 3 air

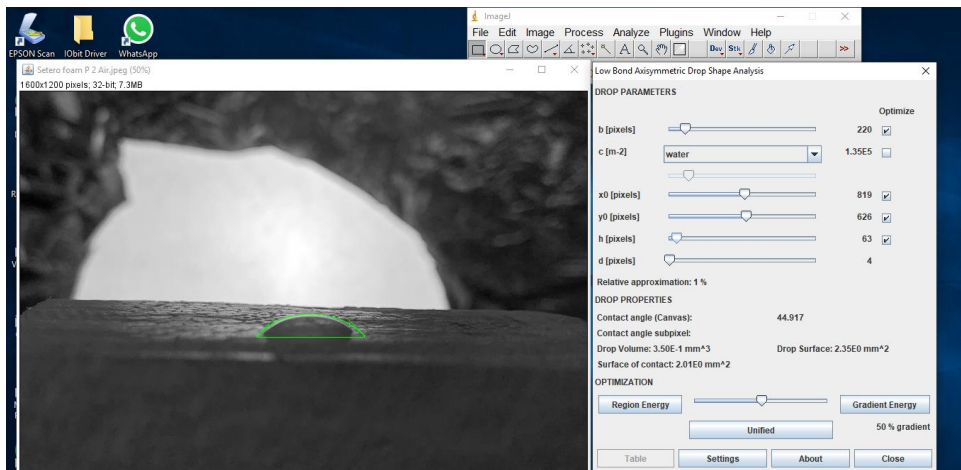

Styrofoam percobaan 1 aquades

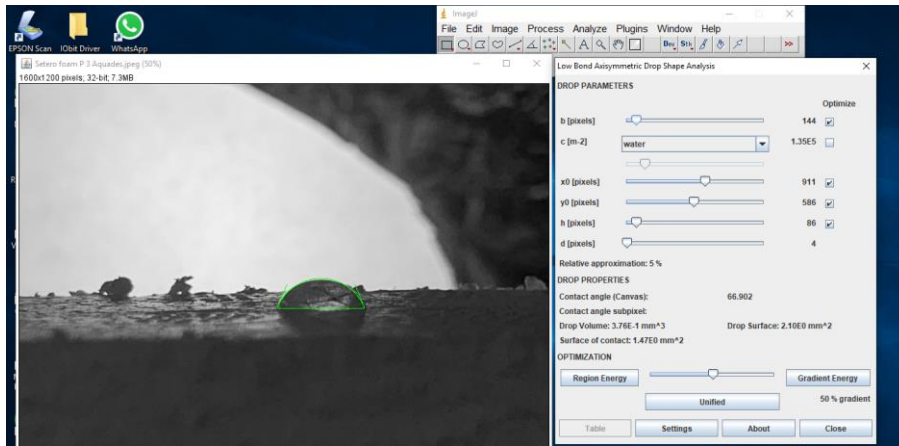

Styrofoam percobaan 2 aquades

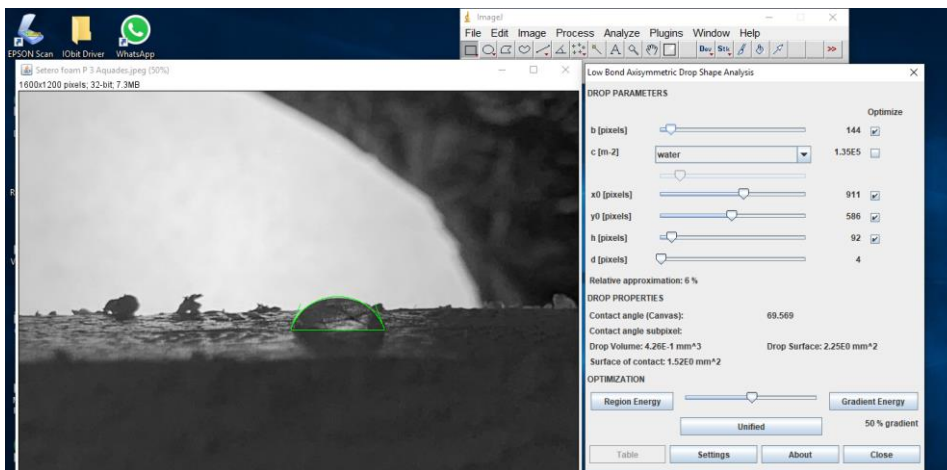

Styrofoam percobaan 3 aquades

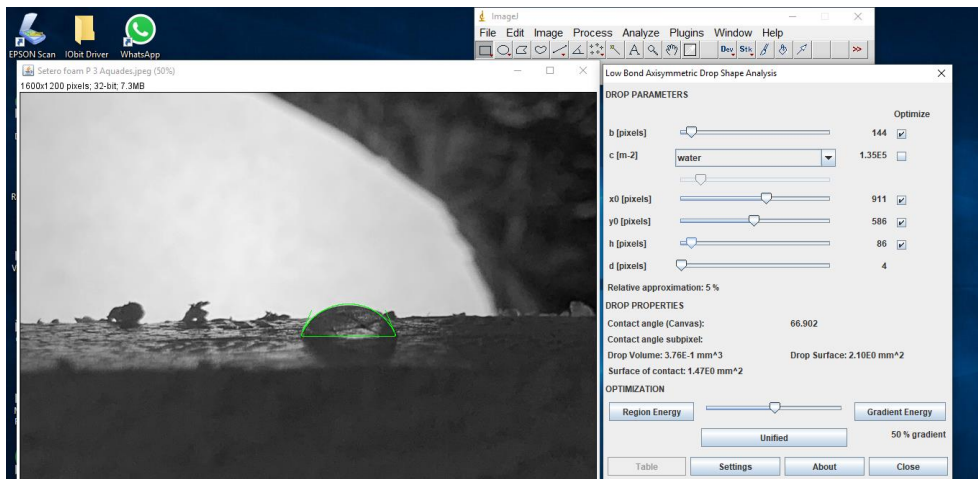

Styrofoam percobaan 1 cuka

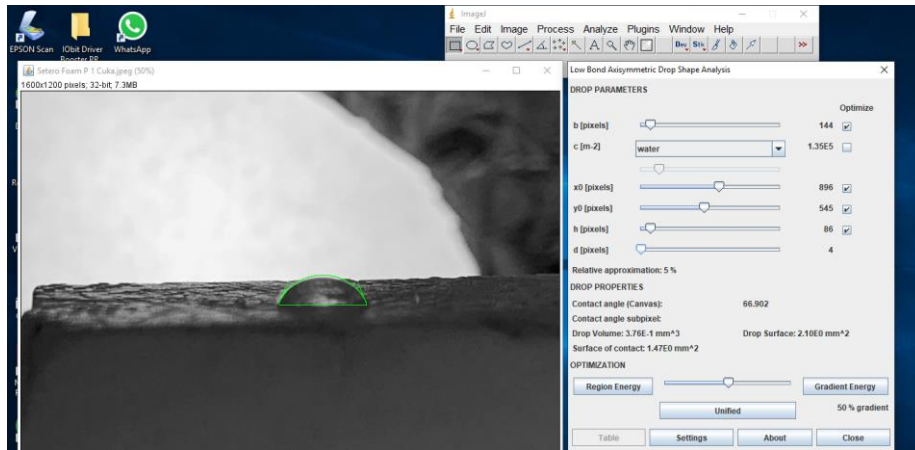

Styrofoam percobaan 2 cuka

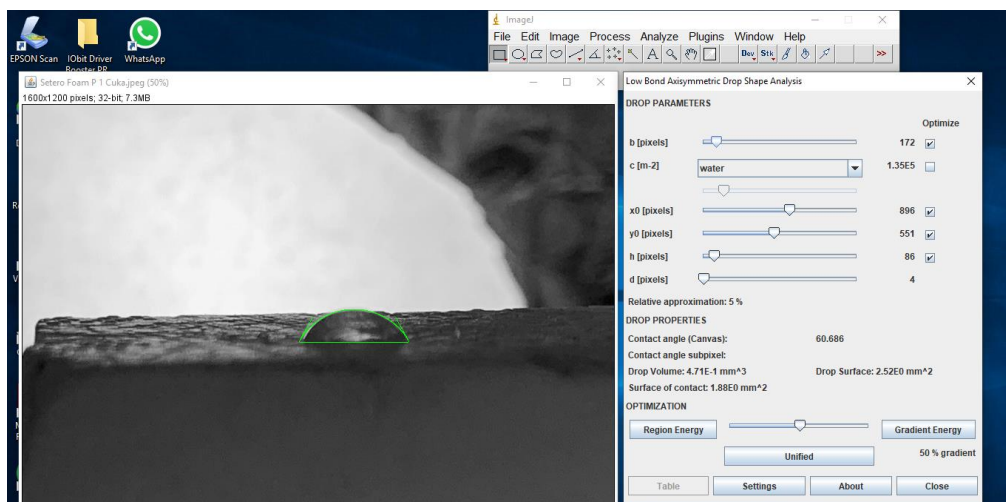

Styrofoam percobaan 3 cuka

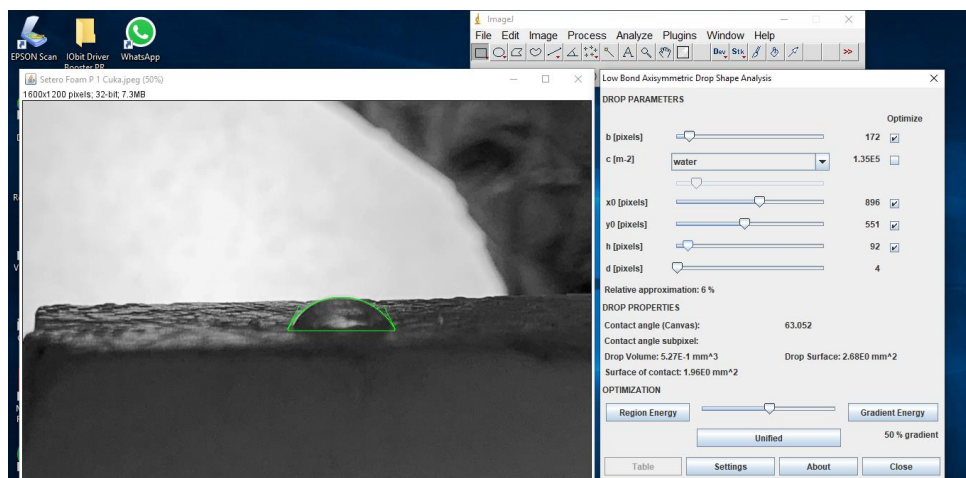

Styrofoam percobaan 1 garam

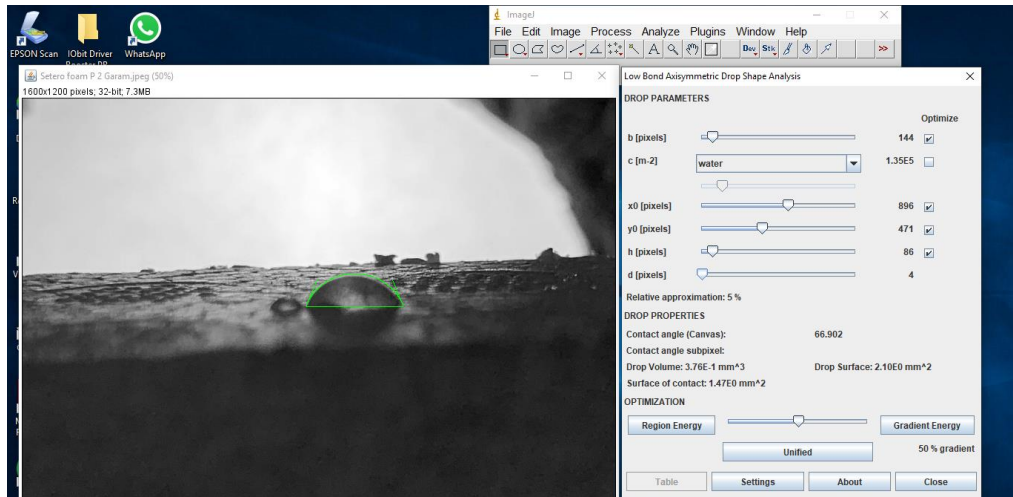

Styrofoam percobaan 2 gram

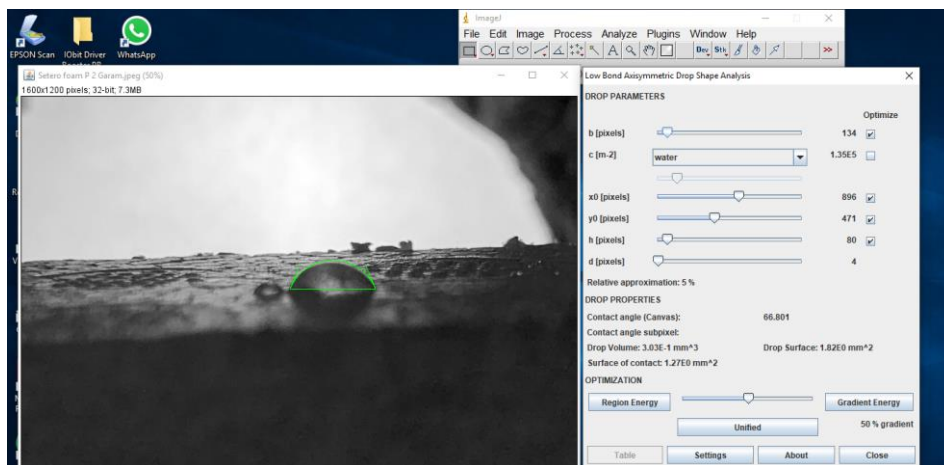

Styrofoam percobaan 3 gram

