

PAPER • OPEN ACCESS

The flame characteristics of the biogas has produced through the digester method with various starters

To cite this article: Caturwati Ni Ketut *et al* 2018 *IOP Conf. Ser.: Mater. Sci. Eng.* **299** 012091

View the [article online](#) for updates and enhancements.

You may also like

- [Greenhouse gas emission of household plastic biogas digester using life cycle assessment approach](#)
A Haryanto and D Cahyani
- [Biogas development: Dissemination and barriers](#)
S Dyah and Sriharti
- [Design and testing of mini-size biogas plant](#)
Erwin Randjawali and Abdul Waris



The Electrochemical Society
Advancing solid state & electrochemical science & technology

242nd ECS Meeting

Oct 9 – 13, 2022 • Atlanta, GA, US

Abstract submission deadline: **April 8, 2022**

Connect. Engage. Champion. Empower. Accelerate.

MOVE SCIENCE FORWARD



Submit your abstract



The flame characteristics of the biogas has produced through the digester method with various starters

Caturwati Ni Ketut¹), Sudrajat Agung¹), Permana Mekro¹), Haryanto Heri²), Bachtiar¹).

¹)Mechanical Engineering Department, ²)Electrical Engineering
Department University of Sultan Ageng Tirtayasa
Jl. Jend. Sudirman km.3 Cilegon - Indonesia 42435

e-mail : n4wati@yahoo.co.id , n4wati@untirta.ac.id

Abstract. Increasing the volume of waste, especially in urban areas is a source of problems in realizing the comfort and health of the environment. It needs to do a good handling of garbage so as to provide benefits for the whole community. Organic waste processing through bio-digester method to produce a biogas as an energy source is an effort. This research was conducted to test the characteristics of biogas flame generated from organic waste processing through digester with various of the starter such as: cow dung, goat manure, and leachate that obtained from the landfill at Bagendung–Cilegon. The flame height and maximum temperature of the flame are measured for the same pressure of biogas. The measurements showed the flame produced by bio-digester with leachate starter has the lowest flame height compared to the other types of biogas, and the highest flame height is given by biogas from digester with cow dung as a starter. The maximum flame temperature of biogas produced by leachate as a starter reaches 1027 °C. This value is 7% lower than the maximum flame temperature of biogas produced by cow dung as a starter. Cow dung was observed to be the best starter compared to goat manure and leachate, but the use of leachate as a starter in producing biogas with biodigester method is not the best but it worked.

Key-words: biogas, bio-digester, starter, flame

1. Introduction

Biogas is a form of energy that is renewable, clean, environmentally friendly and very suitable for use in rural areas. The process of biogas formation is very good occurs in hot environmental conditions. Indonesia is a country located around the equator which has a higher environmental temperature than any other country located far from the equator. Thus Indonesia is very suitable to develop and utilize biogas as an energy source.

The handling of garbage in big cities today is becoming more complicated considering the increasing number of garbage and the narrowness of land used as shelters. Waste shelters that are



getting closer to human settlements cause health problems for the surrounding environment. For that proper handling of municipal waste should get attention.

One of the breakthroughs that need to be developed and applied is the utilization of waste as an energy source. Various research and technology development shows that waste can be processed and used as energy source. [1,2,3,4,5].

Utilization of waste as an energy source can also be done by utilizing the biogas generated from the waste collection system by landfill method [3,5]. The utilization of leachate, wastewater from waste management by landfill method, for improve the quality and stabilize biogas production by recirculated of leachate with splashed leachate on the top of garbage pile [5].

In addition to landfill method of biogas, the formation can be done by anaerobic digester method. But that can be used in this case is only organic waste and animal or human waste. The process of forming biogas in an anaerobic digester is strongly influenced by the composition ratio of C / N in the raw material of biogas. To be able to utilize waste with a very high C / N value can be mixed with other materials with lower C / N values to optimize biogas product [6].

This paper shows the comparison of flame from biogas derived from organic waste with a mixture of starter: cow dung, goat manure, and leachate. This is done to determine the quality of each biogas as a source of energy, especially as fuel.

2. Experiment Details

In this research, we tested the flame characteristic of biogas combustion produced from organic waste biodigester with starter-type derived from:

1. Cow dung
2. Goat manure
3. Leachate

Biogas is produced from organic waste biodigester derived from a mixture of the following materials :

Type	Organic wastes	Water (liters)	Starter
Biogas I	50 liters	25	25 l cow dung
Biogas II	50 liters	25	25 l goat manure
Biogas III	50 liters	-	50 l leachate

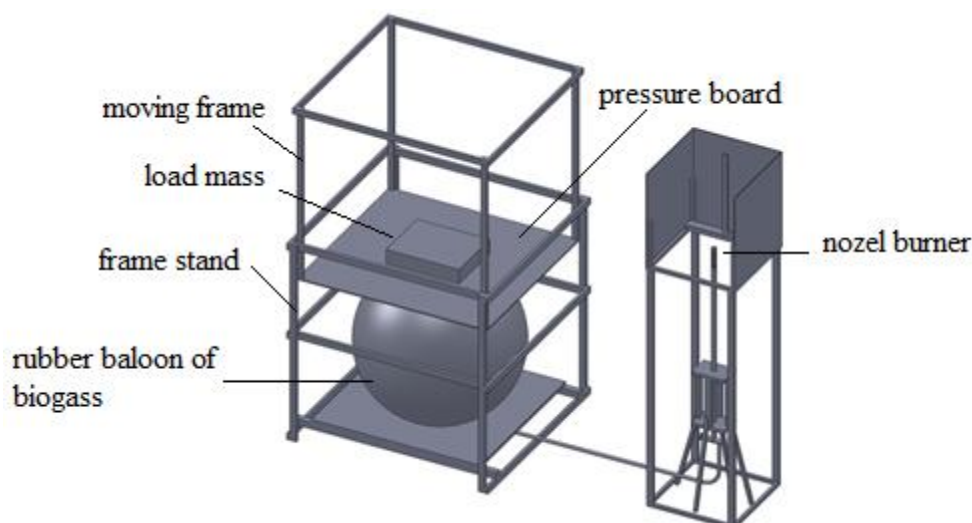

Figure 1. Skecth of flame measuring instrument.

Pressure board : 60 cm x 60 cm x 1,2 cm
 Load Mass : 2690 grams
 Moving Frame : 65 cm x 65 cm x 65 cm

Biogas that has been produced from biodigester is stored in a rubber balloon that has a diameter of 45 cm. In order for biogas to flow into the nozzle of the combustion chamber, it is necessary to increase the pressure inside the biogas balloon, with ballast in the form of a board placed over a gas balloon. By providing a fixed load of the board, it is expected that the gas pressure coming out to the burner is constant. The sketch of the biogas flame test apparatus is shown in Figure 1 .

The measurement of flame dimensions was done using photograph. Figure 2. Shows the dimensional determination of flame by using adobe photo shop from digital photos by comparing the number of pixels on the scale of the ruler with different pixel values on the height of the flame.

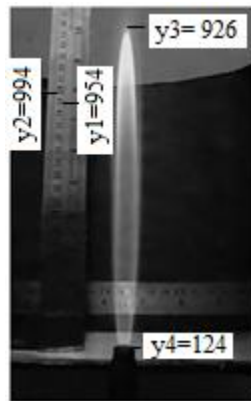

Figure 2. Determining the dimensions of flame through the photo

3. Results and Discussions

3.1 Flames dimensions

The length and width of the flame generated from burning biogas at the same pressure are shown in Table 1.

Table 1. Dimensions of flames: height (Hf) and width (Wf)

Type of starter	Dimension	1	2	3	average
Cow dung	Hf (cm)	21,6	25,4	20,5	22,50
	Wf (cm)	1,8	1,7	1,5	1,67
Goat manure	Hf (cm)	24,1	20,2	21,38	21,89
	Wf (cm)	1,8	2,3	2,25	2,12
Leachate	Hf (cm)	19,5	19,9	18,6	19,33
	Wf (cm)	2,8	2	2,3	2,37

The average flame dimensions are generated from the burning of different biogas from different starter types are shown in Figure 3. The flame of biogas produced from the type of cow dung starter has the highest flame length but has the smallest width of the flame base.

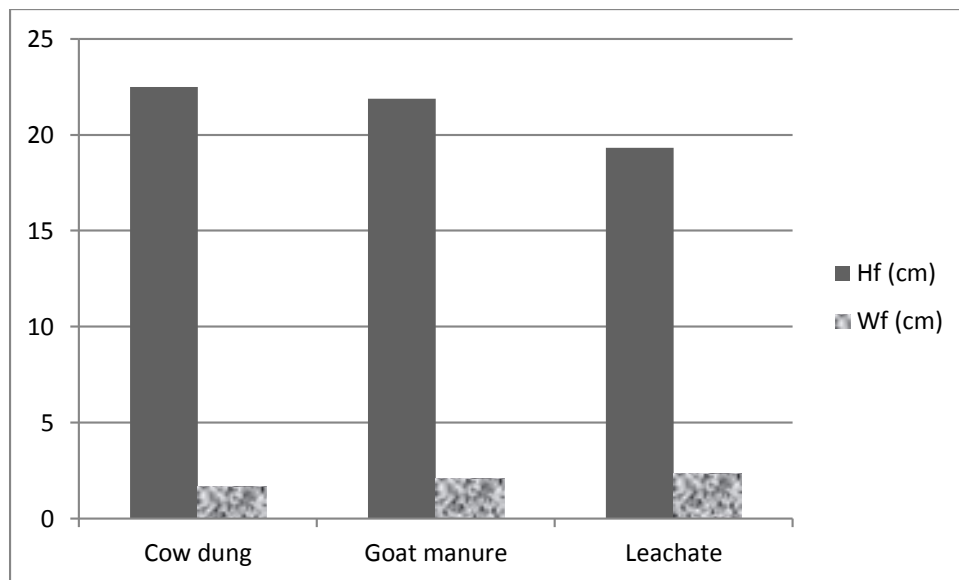

Figure 3. Height and width of flames from biogas with various starters

3.2 Maximum temperature of flames

The maximum temperature of flame from each biogas is measured using a thermocouple. The measurement results are shown in table 2. The table shows that maximum temperature is obtained at the flame of biogas resulting from goat manure starter and the lowest of maximum temperature flame is produced from biogas with leachate as a starter.

Table 2. Maximum temperature of flame

Type of starter	Tmax (°C)
Cow dung	1089
Goat manure	1105
Leachate	1027

3.3 Flame color

In general, the color of the flame on the combustion of biogas from organic waste has a blue color with a reddish yellow mixture. The flame from burning biogas with a starter of cow dung and goat manure has more reddish color compared to biogas from organic waste with leachate as a starter.

4. Conclusions

The flame dimensions of biogas derived from organic waste with some starter variations show an inverse relationship between the height of the flame and the width of the flame. The highest flame will have the smallest flame width. The high flame difference resulting from organic waste biogas with a leachate starter 15% lower than the flame of biogas produced by the starter of cow dung at the same biogas pressure entering the combustion chamber. While the height of the flame from burning biogas with goat litter starter 2.7% lower than the high flame biogas organic waste with a starter of cow dung.

The color of flame from biogas with a starter of cow dung and goat manure has more red color than biogas with leachate starter. This shows that the biogas temperature of the leachate starter is lower than that of the two types of biogas produced from other starter types.

The maximum flame temperature of biogas with leachate as a starter has 7% below the maximum flame temperature of biogas with cow dung as a starter. So that leachate is feasible enough to be used as a starter on the production of biogas from organic waste by biodigester method.

References

- [1] Arthur R, M. F. Baidoo, and E. Antwi 2011 *Renew. Energy* **36** pp. 1510–1516
- [2] Nzihou Jean Fidele, Koulidiati Jean 2014 *Br. J. Appl. Sci. Technol* **4** pp. 450–464
- [3] Caturwati NK, A. Sudrajat, H. Haryanto, P. Mekro, and Aminullah 2016 **2016** pp 364–371
- [4] T. Zhang 2013 *PLoS One* **8** pp 1–8
- [5] A. M. Sunil Kumar, Chart Chiemchaisri 2011 pp 77–79
- [6] Sherwin Amini 2013 *International Journal of Agriculture and Crop Sciences* pp. 1453–1458

Acknowledgements

The authors would like to thank the Ministry of Research Technology and Higher Education Indonesia for financially supported through the Research Innovation Grant 2017.